

**IDS Working Paper 184**

**Subsidy or self-respect?**

**Participatory total community sanitation in Bangladesh**

**Kamal Kar**

September 2003

INSTITUTE OF DEVELOPMENT STUDIES  
Brighton, Sussex BN1 9RE  
ENGLAND

Kamal Kar is a social and participatory development consultant based in Kolkata, India, who has worked extensively with many national and international agencies on innovative methodologies for development in Asia and Africa. He has collaborated with members of the IDS Participation Group, and in April 2002 received a mini-grant from IDS to document his experiences with community-led total sanitation in Bangladesh. Kar presented his findings at an IDS seminar in May 2002, and subsequently produced this report with input and editing from Robert Chambers, Jethro Pettit, Beth Harrison, Shandana Mohmand and Garrett Pratt at IDS, and from the collaborating agencies in Bangladesh including Village Education Resources Centre (VERC) and WaterAid Bangladesh, among many others noted in the author's acknowledgement.

## Summary

Access to latrines in rural areas of Bangladesh is less than 15 per cent. Many international agencies and non-governmental organisations have been working to improve environmental sanitation by constructing latrines and toilets with subsidies provided at different rates. But even after three decades of such efforts it is difficult to find 100 villages from amongst nearly 85,000 that are totally sanitised and free from open defecation. Success has generally been measured on the basis of the number of latrines constructed within a given period of time instead of the extent of open defecation, which in most cases has continued unabated. A new approach being pioneered by the author (Dr Kamal Kar, Social and Participatory Development Consultant from Calcutta, India) with Village Education Resource Centre (VERC), Water Aid in Bangladesh and other agencies concentrates on empowering local people to analyse the extent and risk of environmental pollution caused by open defecation, and to construct toilets without any external subsidies. This community-led effort has had a huge impact. Open defecation has been completely stopped by the community in more than 400 villages in Bangladesh, and the methodology is now being adopted in parts of India and elsewhere in Asia and Africa. This new empowering approach towards the provision of services and infrastructure has serious policy implications for other such programmes. Firstly, financial subsidies from agencies should be used to facilitate and enhance community understanding of the risks of open defecation and to train community catalysts that can spread the programme, rather than being used to invest in material and physical infrastructure. Secondly, agencies must employ a flexible approach in working with communities in order to allow the latter to take the lead in addressing problems in their own way, instead of dictating practices. Thirdly, success must be measured on the basis of the final impact (elimination of open defecation) instead of the final output (construction of toilets of externally prescribed designs). This new approach demonstrates the impact a simple facilitative process can have on changing age-old practices, where the onus for progress is placed almost entirely on the community.



## Contents

	Summary	iii
	List of figures and tables	vi
	Acknowledgements	vii
	Abbreviations and acronyms	ix
<b>1</b>	<b>Background</b>	<b>1</b>
	1.1 Subsidised sanitation sector	2
	1.2 Initiation process	3
<b>2</b>	<b>Participatory total community sanitation</b>	<b>4</b>
	2.1 Ignition process using Participatory Rural Appraisal	4
	2.1.1 Defecation area transect	5
	2.1.2 Sanitation mapping, collective calculation and flow diagrams	6
	2.1.3 Visual tools	7
	2.1.4 Planning for collective and household action and implementation	7
	2.1.5 Children as agents of change	8
	2.2 Facilitation – the key to achieving participation	9
	2.3 Explosion of innovative models of toilets	11
	2.3.1 Barefoot engineers	14
	2.4 Community catalysts	16
	2.5 Community consultants	17
	2.6 Social dynamics and group formation	18
	2.7 Declaring villages as 100 per cent sanitised	20
<b>3</b>	<b>Impact of the project</b>	<b>22</b>
	3.1 Impact on livelihoods	22
	3.2 Impact on women	23
<b>4</b>	<b>National and international spread</b>	<b>24</b>
<b>5</b>	<b>Points of departure</b>	<b>27</b>
<b>6</b>	<b>Limitations of the approach observed to date</b>	<b>28</b>
<b>7</b>	<b>Lessons learnt and recommendations</b>	<b>29</b>
	<b>Annex 1 Community innovated toilets</b>	<b>31</b>
	<b>Bibliography</b>	<b>40</b>

## Figures

Figure 2.1	Process of community realisation and action towards a sanitised village environment	8
Figure 2.2	Sequential process applied in the villages by the field facilitators team	11
Figure 2.3	Mapping of village household and hygiene dynamics, and social processes stimulated by Entry PRA (Ignition PRA) for moving towards a 100% sanitised village	19
Figure 4.1	Social map of Choobana village, Monze district, Zambia showing all the households with and without latrines dish racks and refuse pits	26

## Tables

Table 2.1	Comparison between CIMs and other low-cost models	12
Table 2.2	Community innovations identified and documented so far from different areas of the programme	15
Table 2.3	Communities declared open defecation-free under Community Led Total Sanitation in Bangladesh (as reported by participating organisations)	21

## **Acknowledgements**

Community led total sanitation without the use of subsidies has become a reality in many villages in Asia and Africa. Evolved in Mosmoil village in Rajshahi district in Bangladesh the approach has now empowered rural communities in many areas of India, Bangladesh, Cambodia, Zambia and Uganda and it continues to spread spontaneously from village to village.

With the active involvement and committed work of many local, national and international agencies and institutions it has been possible to develop and spread the community led total sanitation approach to rural communities where open defecation is still practised. I would like to convey my most sincere thanks to all of them and acknowledge their sincere participation in carrying the approach forward. The key institutions who played a major role are: Village Education Resource Centre (VERC) (Bangladesh), WaterAid Bangladesh (WaterAid-B), Plan (Bangladesh), Integrated Food Security Programme (IFSP) of CARE- Bangladesh, Rural Advancement Committee for Bangladesh (RAC-BD), Gramalaya, Tamilnadu (India), Water and Sanitation Programme, South Asia in New Delhi and Dhaka (WSP-SA), Government of Maharashtra (India), Zilla Parishad of Ahmednagar (India), Zilla Parishad of Nanded districts (India), Concern Worldwide (Cambodia), Commune Council of May Tuk in Pursat province and Seam Reap (Cambodia), District Administration of Kibale district (Uganda) and Water, Sanitation and Hygiene Education Programme for the 21<sup>st</sup> Century (WASH-21) project of United Nations Development Programme (UNDP) (Mongolia). A number of community based organisations, informal groups and members of village communities played commendable roles and participated in evolving this approach. I convey my heartfelt gratitude to all of them. Names of the community members who innovated many low cost latrine models are mentioned in Annex 1 along with diagrams of their innovated models. I am sure there are other institutions that are engaging themselves in the spread and scaling up of the community led total sanitation approach to hundreds of villages and slums. I apologise for not being able to mention all the names.

I would like to especially thank a few individuals for their enthusiasm, help and cooperation during the development stage of the approach. Many of them belong to the above-mentioned institutions. They are Adil Ahmed, Clarissa Brocklehurst, Mimi Khan, Simon Trace, Ravi Narayanan, Peter Sinclares, Towhida Yesmin, Timothy Claydon, Yakub Hossain, Masud Hassan, Paritosh Chandra Sarkar, Quamrul Islam, Tapan Kumar Saha, Abu Zaher, Rezaul Huda Milon, Robiullah Rabi, Abu Sayem Hossain, Robiul Islam, Bina Gazi, Ashraful Islam, Momena Khatun, Yousuf Ali, Humayun Kabir, Rafiqul Islam, Rahima Aktar, Shamsun Nahar, Forman Ali, Atahur Rahaman, Bashir Ahmed, Shamaresh Majumder, Noor Mustafa, Theresa McDonnell Fristrom, Mohammad Mobin, Mark Munoz, Kim Miratori, Pich Sophary, Sarah O'Boyle, Edgar Montalban, Alka Pathak, Nargis Soma, Khandakar Zakir Hussain, Liakat Ali, Ekramul Kabir, Sekhar Bhattacharaya, Safiqur Rahman, Aminur Rasul, Kamruzzaman, Nur Mahamad Ilias, Tahera Yasmin, Fatima Khatun, Fatema Kana, Safiqul Islam, Ebadur Rahman Badal, Khairul Islam, Nazrul Islam, Razzaqul Alam, Sabber Ahmed, B.C. Khatua, S.D. Thakre, Soma Ghosh Mouluk, J.V.R. Murty, C Ajith Kumar, Damodaran, Vivek Srivastava, C.K. Dhalvi,

V.S. Nahata Lahu Kanade, Junaid Ahmed, K. Minnatullah, Safiqul Islam, John and Sue McDermott, Carol Hannon, Andrew Mownze, Otto Farkas, Gansukh Gongor, Tungalag Ulambayar, Buzmaa Avirmed, Borchuluun Urtnasan, Swati Kar and Satwik Kar.

I would like to convey my heart felt thanks to Professor Robert Chambers for his endless support and enthusiasm all through the process of development of the approach and its documentation. The rural community has proved it once again what Robert said in his book *Whose Reality Counts* years ago.

I am grateful to Shandana Mohmand, Jethro Pettit, Beth Harrison and Alison Norwood at the Institute of Development Studies, Sussex for their contribution in editing and preparing the paper. I am also thankful to all those who provided valuable suggestions on the draft of this paper.

Kamal Kar  
IDS, Sussex and  
Kolkata, September 2003



## Abbreviations and acronyms

ASEH	Advancing Sustainable Environmental Health
BBS	Bangladesh Bureau of Statistics
BRAC	Bangladesh Rural Advancement Committee
CBRD	Capacity Building for Rural Development
CIM	Community Innovated Model
DANIDA	Danish Agency for Development Assistance
DALYS	Disability Adjusted Life Years
DFID-B	Department for International Development – Bangladesh
DWASHE	Department of Water and Sanitation
EHT	Environmental Health Technician
HM	Health Motivator
IFSP	Integrated Food Security Programme
LMP	Livelihoods Monitoring Project
NGO	Non-Governmental Organisation
PG	Primary Groups
PRA	Participatory Rural Appraisal
RCC	Reinforced Cement Concrete
ROSCA	Rotating Savings Credit Associations
RSEG	Rural Sanitation Engineering Group
TW	Tube Well
U5MR	Under-five Mortality Rate
UNICEF	United Nations International Children’s Emergency Fund
UNDP	United Nations Development Programme
VERC	Village Education Resource Centre
WASH-21	Water, Sanitation and Hygiene Education Programme for the 21 <sup>st</sup> Century project of UNDP, Mongolia
WaterAid-B	Water Aid Bangladesh
WATSAN	Water and Sanitation
WELL	Resource Centre Network for Water, Sanitation and Environmental Health (UK)
WHO	World Health Organisation
WSP-SA	Water and Sanitation Programme, South Asia



## **1 Background**

Practices such as open defecation, unhygienic behaviour and haphazard garbage disposal are common in South and South-East Asia, Africa and Latin America. They result in environmental degradation which directly affects the health and quality of life of millions of people, especially the poorest, most vulnerable people in these regions.

The situation is acute and widespread in much of South Asia, where a significant proportion of the population bears the burden of disease that is attributed to inadequate access to and use of safe drinking water, inadequate sanitation facilities and unhygienic practices. In large parts of Bangladesh people in both rural and urban areas practice open defecation. Men squatting for defecation on both sides of the roads, railway line, or in open fields and bushes are very common scenes in the mornings and in the evenings in many parts of the sub-continent. Women also defecate in the open but are obliged by customary modesty to do this only before dawn or after dark when they will not be seen.

As a result it is often difficult to walk along the rural village paths without stepping on human excreta, especially in the rainy seasons when hanging latrines overflow and mess up the village paths and roads. An added hazard is the smell of years of accumulated human excreta in bamboo plantations, bushes, orchards and sugarcane fields.

The scenario in urban slums is even more devastating. People defecate in plastic bags and dispose of them in the streets and in open spaces. In the Philippines, slum dwellers used to throw plastic bags full of human excreta on the roofs of trains for disposal. In response to this, the railways changed the style of roofs and made them slant on both sides so that the bags would not get lodged on the roofs. People then innovated other techniques of disposal using the same trains. They tied two plastic bags with a thread and threw them in such a way that they were lodged on the cliff edge of the train roofs.

All these practices, coupled with a total absence of hygienic behaviour, heavily contaminate the drinking water sources and the environment as a whole, including ponds, other water bodies, and crop land. Diarrhoea, cholera, typhoid and a number of other enteric diseases are regular phenomena in many countries which affect millions of people and often take the form of epidemics killing thousands. In Bangladesh, more than 15 per cent of the under-five mortality rate (U5MR) is due to diarrhoeal disease and in many communities 40 per cent of the overall morbidity is due to water and sanitation related diseases, according to the World Health Organisation (WHO). Links between the incidences of diarrhoea in children under five years old is positively associated with the index of household vulnerability, levels of under-nutrition and the number of children under five within the household

The Department for International Development-Bangladesh (DFID-B) and CARE Bangladesh North West Baseline Livelihoods Monitoring Project (LMP) noted recently that communities reported over 65 per cent of their disease burden as water and sanitation related. Due to dismal and inadequate sanitation and very poor hygiene practices high incidence in diarrhoeal and other water related diseases cause 115,000 child deaths each year (11 per cent of total deaths) and the loss of 5.75 million disability

adjusted life years (DALYS)<sup>1</sup> or 61 per cent of total lost DALYS. Of these DALYS, 90 per cent were attributed to environmental causes and 65 per cent of the DALYS could be averted through improvements in water supply and environmental sanitation, including latrines, drainage, garbage disposal and hygiene. In addition to the human costs, the economic losses associated with these practices (diarrhoeal diseases, treatment, mortality, morbidity and labour days) have a major impact on the economy.

Treatment of hygiene-related disease costs 5 billion Taka (£60 million) each year. Studies from India indicate significant reductions in monthly medical expenditure (from £12 down to £1.50) following integrated urban water, hygiene and sanitation intervention. Loss of earnings and production are additional handicaps for poor people, whose physical fitness is their main productive asset.

Access to latrines in Bangladesh is officially stated to be 53 per cent, according to WHO/United Nations International Children's Emergency Fund (UNICEF) for combined rural and urban communities and 37 per cent (according to the Bangladesh Bureau of Statistics) for rural communities. However, these figures include "hanging latrines"<sup>2</sup> which are not sanitary and merely mean that people are practising open defecation but in a fixed place. The more realistic estimate for latrines in rural areas is less than 15 per cent. In many villages, non governmental organisations (NGOs) working in the water and sanitation sector have found the latrine coverage at 5–7 per cent during pre-intervention surveys. An estimated 20,000–25,000 metric tonnes of human faeces is being added every day in open areas, contaminating water sources and causing serious health hazards.

### **1.1 Subsidised sanitation sector**

Millions of dollars are being spent every year on the water and sanitation sector in countries such as Bangladesh by a number of international development agencies, including UNICEF, United Nations Development Programme (UNDP) and the World Bank Water and Sanitation Programme, South Asia (WSP-SA). Additionally, a large number of national and international NGOs are working on water and sanitation with support from the donor agencies.

Most agencies working to improve environmental sanitation spend resources on motivating people to construct latrines and toilets with subsidies provided at different rates. NGOs train and motivate villagers on good hygiene practices and on ways of treating diarrhoea. Protection from diarrhoeal diseases is explained by the external agencies to the local people, who are then motivated to construct toilets from amongst the prescribed models. In Bangladesh, hundreds of NGOs have become engaged in this sector but after thirty years of such efforts it is difficult to find even 100 villages from amongst nearly 85,000 that are 100 per cent sanitised and totally free from open defecation.

---

<sup>1</sup> DALYS – Disability Adjusted Life Years, a measure of effective loss of life through both death and incapacity.

<sup>2</sup> A hanging latrine is made of two planks laid over a hole, usually behind the house, that is then used as a designated spot for defecation. It is considered another form of open defecation and all hanging latrines in the villages that participated in this project have now been removed.

Some changes, however, have taken place as a result of intervention by different agencies. The number of latrines in villages has increased and more water seal latrine slabs and concrete rings have been sold. People who could afford to do so constructed ring-slab latrines. NGOs have innovated many ways to motivate people with subsidies and loans to construct toilets choosing from at least three models, all designed by outsiders. However, even with large amounts of subsidies, it has not been easy to convince people to construct their own toilets and stop open defecation. There have been many obstacles, such as lack of ownership of land for construction of a toilet, insufficient water for flushing the toilet after use, and high costs of the pre-fabricated models and the superstructure. Despite this, NGOs concentrated on building toilets and success was measured on the basis of the number of latrines constructed within a given period of time instead of measuring the extent of open defecation, which in most cases continued unabated. Successful NGOs were more concerned with their area coverage and specific programme interventions than on the final impact of their projects. While some organisations extended loans for latrine construction, others made it a precondition for accessing funds for programmes such as micro-credit for income generation. However, sanitation generally remained a low priority sector for donors as compared to other areas and concerns.

## **1.2 Initiation process**

In 1998, WaterAid, a UK-based international organisation, requested me to lead a participatory impact assessment of their ten-year old water and sanitation programme being implemented by their partner Village Education Resource Centre (VERC) in Bangladesh. A four-member international team carried out the evaluation in early 1999. Since it was a participatory impact assessment at least seven members of the staff from different levels of VERC and specialists from Water Aid-B were included in the evaluation mission. They were given new roles as consultants and were trained on the methodology and design of the participatory impact assessment. The team visited four districts of Bangladesh (in the north and south of the country) and carried out participatory exercises with at least 30 rural communities.

The evaluation revealed several new dimensions. While the levels of poverty varied through the country, the percentage of subsidy for toilet construction given by VERC and WaterAid-Bangladesh (WaterAid-B) was the same everywhere. Also, while the target of toilet and hand pump construction was achieved by VERC, the mission did not find a single village with absolutely no open defecation. People did construct toilets but open defecation remained rampant. Pockets of households in villages were found where the percentage of households with latrines was more than the rest of the villages. However, these new toilets constructed with subsidy belonged mostly to better off and middle order families.

The evaluation made two main recommendations amongst others. The first was to undertake a participatory poverty assessment and, on the basis of the levels of poverty, determine a subsidy strategy for toilets. Instead of a single subsidy strategy for the entire country, it was recommended that a differential strategy be developed that takes into account location and income levels. The second was to develop a strategy to gradually withdraw subsidies for toilets. One year after this evaluation WaterAid-B

commissioned a countrywide assessment of poverty in the rural areas to decide a differential strategy for subsidy on toilets and requested my help in the exercise.

The team that facilitated the assessment of poverty through a participatory study kept an open mind. Efforts were made to empower the community to analyse their own situation of environmental sanitation and the reasons why many people had not constructed latrines in spite of subsidy. We endeavoured to understand the situation from the perspective of women and the weaker sections of the community, and the difficulties they face. For the first time we realised that ‘outsider motivated external subsidy-oriented toilet construction’ was a far cry from what might take the form of ‘total sanitation of the village by catalysed participation and self-mobilisation’.

This exercise of understanding the levels of poverty and its relation with open defecation, environmental sanitation and use of toilets, using methods of participatory rural appraisal (PRA), revealed completely new realities (Kar, Ahmed, Saha and Yesmin 2000). The study made us realise that the subsidy approach had built-in elements which prevented total community sanitation. First, the landless were excluded because they had no land for toilets. Second, poorer people were excluded by costs of construction: the subsidy was in kind, usually in the form of a cement slab, and the few toilet models offered by the project were expensive to build. Third, some of those who were better off waited to see if they could get the subsidy instead of going ahead and constructing toilets of their own. In sum, the subsidy approach was self-defeating from the point of view of total community sanitation. The approach we decided to explore was radically different, without subsidy, and based on facilitation to catalyse community self-help.

## **2 Participatory total community sanitation**

### ***2.1 Ignition process using Participatory Rural Appraisal***

The new findings were incorporated into VERC’s approach and it began a process of transformation. The same facilitating team that had carried out the participatory poverty assessment now became involved in the development of methodology for the new ‘no subsidy community empowerment approach’ and it was, thus, easy for them to compare the two different approaches. The team comprised the field staff from VERC (mostly Area Programme Coordinators and Health Motivators) and Social Development personnel from WaterAid-B. They were trained to focus on empowering all members of the community to analyse the environmental sanitation conditions of the village. After extensive orientation and field trial of the process and methodology of this new approach, the facilitators were divided into four teams to undertake activities in four different study areas. An experienced external facilitator accompanied each team. All the teams had total liberty to apply the methods flexibly according to the local context. Initially, the approach was tested in villages where VERC was already working and, therefore, had a rapport with the community.

Since the first experience with a small village in Rajshahi district in March 2000 the programme has spread dramatically and there has been no looking back. Today, more than 400 villages have totally cleaned themselves up, covering more than 16,000 families in at least six districts from the north to the south of Bangladesh. In all of these villages Water and Sanitation (WATSAN) committees have been formed that are functioning voluntarily and monitoring the change. Very soon a few Unions<sup>3</sup> will be declared as totally sanitised where no one practices open defecation.

### *2.1.1 Defecation area transect*

The way in which the community is motivated and the projects initiated is quite unique. The team of facilitators found that a strong impetus for the start of the project came from a simple walk around the village. At some point the team would take all the participating members of the community on a transect walk through the village during which all the different types of latrines used by different households were visited. During this walk, the group would stop in some places where people generally defecate openly. The team discovered that during such transect walks<sup>4</sup> the accompanying members of the community felt very embarrassed to visit these dirty spots with the dignified outsiders. They attempted to move the facilitators away from the area but the more the community tried to move them on, the more they would stop and ask questions. For example, facilitators asked which families used this spot for defecation, what happens during emergency defecation at night or during seasons of high incidence of diarrhoea? The questions were answered at these areas with everyone's hands covering their noses.

These transect walks proved to be the single most important motivating tool. The initial embarrassment experienced by the community during the "walk of shame" gave way to a strong desire to stop open defecation and to get rid of these areas. Generally, when outsiders are taken around the village the community focuses only on the positive aspects and achievements, and this gives them a sense of pride. These transect walks, on the contrary, revealed a different reality. Although everyone saw the filth and dirt everyday, they seemed to have only really awakened to the problem when visiting with groups of outsiders who analysed the situation in such great detail. The transect walks ends with a procession of all the members of the community who attended. Children, in particular, play a crucial role by chanting slogans to stop open defecation. They even developed their own slogans after they had internalised the dangers of open defecation. The parents always felt embarrassed when their children pointed out the facts. While members of the community (particularly women and adolescent girls) listen to the slogans and see the spirit of the procession, they begin to think about the issue.

In almost every case these walks ended in setting up a date and time for the first meeting of the community to discuss a solution to the problem of open defecation.

---

<sup>3</sup> A Union is a local government unit consisting of 11–15 villages.

<sup>4</sup> Transect walks are a common PRA method used to identify and discuss features of the social or natural environment.

### *2.1.2 Sanitation mapping, collective calculation and flow diagrams*

During the first meeting of the community a mapping exercise is generally initiated, where the community maps all the households of the village, and indicates whether or not they have toilets. Next, common places in the villages visited by the households for defecation are marked on the map and are connected to the households that visit that particular spot for defecation purposes. Defecation maps and defecation mobility maps, a map that traces contamination patterns are prepared by the community to see how ponds and other water sources become contaminated (see picture). Such maps also allow a pattern of use to emerge.



*Village woman showing the main defecation areas of the village on a map drawn by the community in Surajgaon village, Ahmednagar district in Maharashtra state, India. Names of the heads of households are written on pieces of paper and connecting lines indicate the area used by that household for defecation.*

The community then carries out a collective calculation of faeces contribution per household in a facilitated process. Households pick their own method of calculation to give a numeric value to how much each house is adding to the problem. This is an interesting and participatory awareness raising tool that allows communities to realise the magnitude and extent of the problem. People start from an initial unit of measurement per person, and then keep multiplying to calculate contribution per family, per week, per month, per year, and so forth. Some even calculate the total amount of human excreta added over the last ten years, and these numbers both surprise and motivate them to curb the spread and addition. Some of the units of measurement used are quintals, tons, cart loads (Rajshahi), and boat loads (Borisal) among many others. In Mosmoil village of Rajshahi district and in Barakumira village of Chittagong district, the community calculated that 50,000 and 120,000 tons respectively of human excreta were being added to their villages every year. The communities are generally horrified by such figures and they immediately start to wonder about the various routes of contamination. Flow diagrams are drawn at this stage to trace these routes to ponds, household utensils, domestic articles and, most importantly, food through flies, chicken and pets. Shocking facts often emerge from people's analysis, which include the revelation that



each person was ingesting faeces of about 1–2 tola<sup>5</sup> in some form everyday. Such revelations bring with them a feeling of abject dejection and people want to start doing something about it immediately. The tempo builds up and people start talking about the way forward and about plans to mitigate the problem.

### ***2.1.3 Visual tools***

WaterAid-B with the help of its partners and other organisations in Bangladesh and abroad developed some visual participatory learning tools to sensitise and ensure active participation within the community. These tools contain visual messages to help communities understand the use of basic hygiene and environmental sanitation practices. They enable people, particularly women, youths and children to analyse their environmental situation and initiate improvements. The process of community mobilisation also includes a number of interactive sessions using these participatory analytical tools. These are instrumental in deepening knowledge and changing hygiene and sanitation habits.

### ***2.1.4 Planning for collective and household action and implementation***

After about 2–3 hours of intensive PRA exercises in groups, the positive force to deal with the situation starts emerging and people start voicing their eagerness to stop open defecation. This is when the planning exercise begins spontaneously and the external facilitators help in the process. In most cases the community forms a committee and decides on an action plan. The members of the committee vow to complete construction of their homemade latrines within a week and take the responsibility for persuading 10–12 households in their neighbourhoods to do the same (see Figure 2.1). In most cases female schoolteachers and religious leaders were found to take the lead.

The process of planning generally concentrates on some immediate positive action plans, which include activities like:

- formation of a Sanitation Action group;
- listing of all households identifying their present sanitation status (having or not having a toilet);
- digging pits and using them as makeshift latrines until they construct a permanent (sanitary) one;
- developing individual family plans to stop open defecation;
- commitments by better-off and middle order households to start constructing latrines immediately;
- looking for external agencies to supply latrine construction materials;
- imposition of community penalty on those that continue to practice open defecation;
- discussing the subject in religious gatherings and community meetings;
- arranging self-organised processions in the neighbourhoods for awareness-raising;
- involving mothers to educate their children to stop defecating in open areas.

---

<sup>5</sup> A tola is a South Asian unit of measurement equivalent to 11.66g.

**Figure 2.1 Process of community realisation and action towards a sanitised village environment**

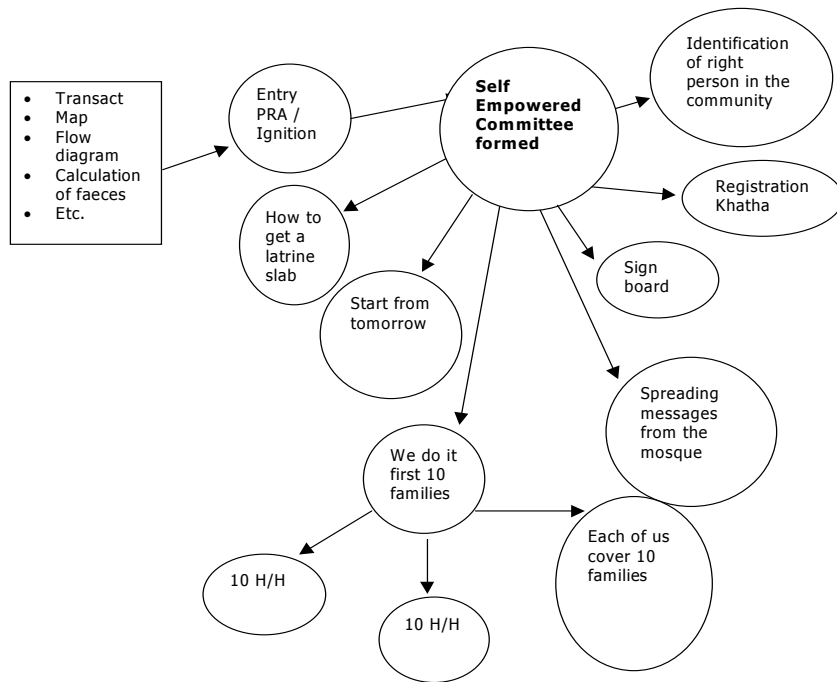

*This diagram represents the processes and stages of community realisation and actions wherein the community volunteered to move towards achieving a totally sanitised village. The facilitating NGO must learn to empower and support the community volunteers in their own endeavours.*

Very interestingly, it was noticed that financial wellbeing influences the type of plans adopted for constructing toilets. Those who can afford it start obtaining information on the availability of hardware like rings, latrine slabs and pans from outside sources, while those who cannot afford to purchase the costlier hardware start planning homemade toilets, digging pits, using bamboo and wooden planks and other locally available materials. The freedom to innovate and experiment leads to the opportunity to choose, and people are able to pick toilet models based on their capacity.

It was also found that no one during the planning process talks about subsidies unless some kind of subsidised programme is already being implemented by an agency there. In that case, it becomes easier for the agency to complete its quota of toilets in that particular village because it no longer has to motivate people to purchase latrines from the agency. Instead the people who can afford or fulfil the criteria for that particular programme become motivated and request latrines themselves.

### **2.1.5 Children as agents of change**

Children are the most active in this process of change. It was found that even after the transect walk, procession and PRA exercises, children started digging holes for latrines and demolishing open defecation sites. This encourages the adults in the community to be proactive and responsive to the approach. The children organise routine village processions, collect baseline information, show and flag defecations sites and disseminate information, especially to their friends. They influence their parents to build toilets.



*Children of Raipara village in Rajshahi, Bangladesh digging a pit for a latrine just after completion of the PRA ignition session in their village.*

## **2.2 Facilitation – the key to achieving participation**

Continuous facilitation at three different levels was being done to support and sustain the new initiatives:

- 1 facilitation at the community level (for a clear analysis of the situation by the community themselves for self mobilisation);
- 2 facilitation at the implementing agency level (to create a more enabling organisational culture for the field staff to work freely and be able to empower the village community);
- 3 facilitation at the donor agency/government level (for rendering the right kind of support and help to the implementing agency/department, reducing domination, prescription and rigidity and sensitising the bureaucracy and senior staff towards participatory and decentralised decision making.

Without these three levels of facilitation working simultaneously, it would not have been possible to scale up small success to larger areas). The third level was also very useful in the scaling up of the approach and in mainstreaming it within the local government systems. If the approach initiated by the NGO with the local community's participation is not mainstreamed into the government structure, it would not be a sustainable approach and it would be difficult to build ownership amongst all the actors.

Skilled facilitation is perhaps the most important element in enhancing community participation. Regardless of how comprehensive the method that is used in involving the community in appraisal, planning, implementation or evaluation, a great deal depends on the capacities of the facilitators. Even the best methods often fail to yield good results or to evoke adequate community participation due to poor facilitation skills. This, of course, does not mean that only highly experienced facilitators can do the job. Once trained, junior level NGO field staff have performed well. What is required is a relaxed, frank and transparent facilitation style with no hidden agendas of selling toilets or fixing some kind of agreement with the community at the end of the day. The right attitude and a sensitive, articulate nature is very important (see picture).



*Good facilitation – the key to ensuring community participation.*



*Participatory Evaluation in WATSAN in progress in Chobana Village of Monze District, Zambia, November 2000.*

Globally, there are many examples where PRA approaches have been successful in building community ownership of programmes to bring about sustained improvement in areas like agriculture, rural development, health, urban poverty and slum improvement. In most cases, community participation has been initiated by external agencies (sometimes with input support) and often it has not been too difficult to involve all the communities within the project areas. However, the scaling up and self-spreading of the success of community participation to wider areas has remained difficult to achieve. There are few examples of participatory analyses creating a deep realisation amongst the communities and triggering sustained and self-spreading community action without external help. In the case of environmental sanitation where open defecation is a century old practice and a very serious problem, and where large sums of money are being spent by international and national development agencies as subsidies to assist the poor in toilet construction, such total community mobilisation is even more rare. That is why it is even more impressive that good facilitation was able to involve the entire community in taking up action plans for total village clean up.

**Figure 2.2 Sequential process applied in the villages by the field facilitators team**

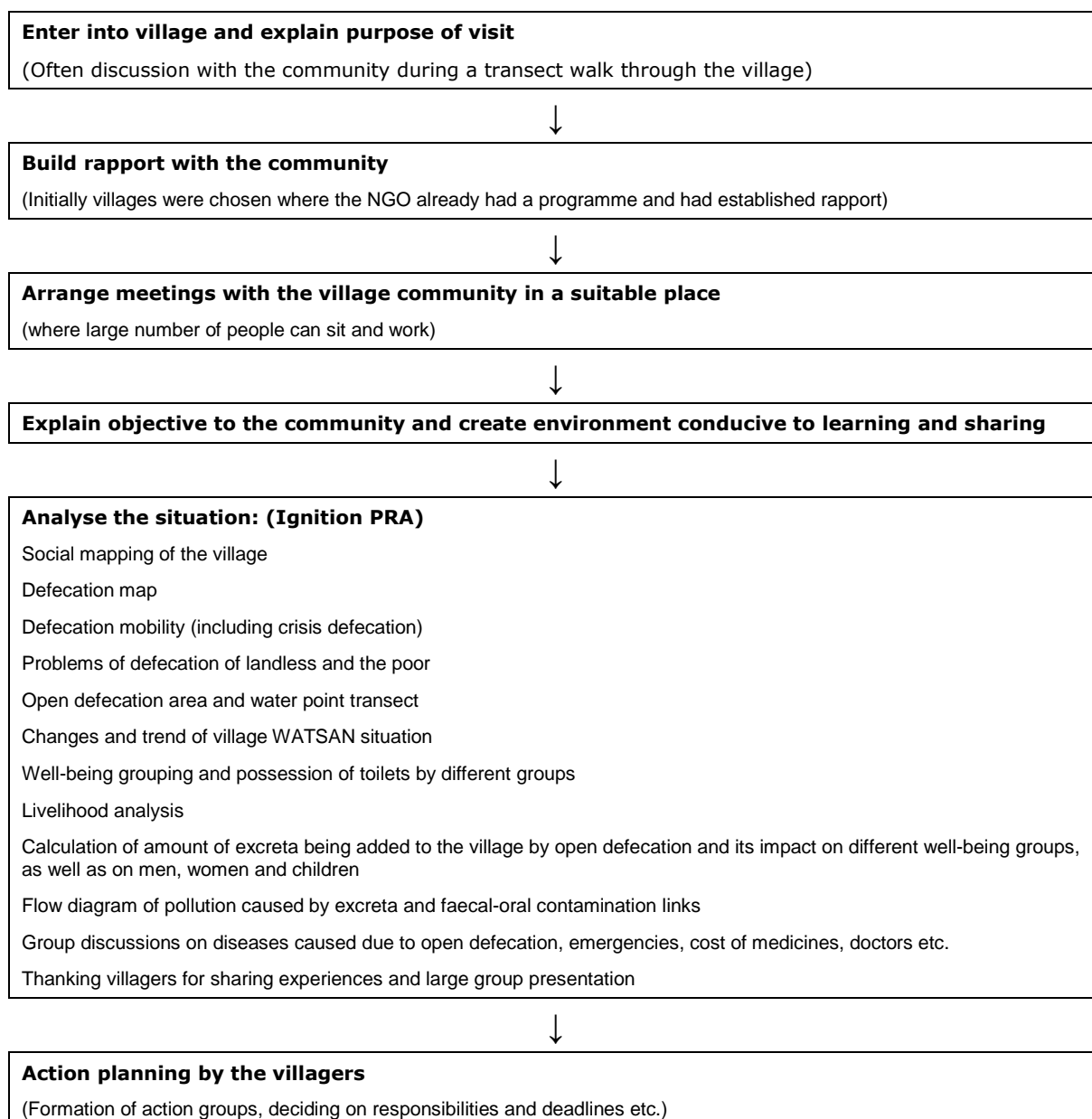

### **2.3 Explosion of innovative models of toilets**

As the community becomes motivated, each member attempts to construct a toilet within the family's means and capacity. Since the obligation to choose from 3–4 models of externally designed toilets no longer exists, community members innovate freely with their own designs of toilet models. Due to timely facilitation and empowerment of the community to innovate, many technical, social and economic innovations have taken place that would have been difficult to imagine in the beginning. For example, the communities designed many local and low-cost models of toilets. All these were designed to be affordable

and to suit the local conditions of the community. Such explosion of local level innovations occurred only when the local community was encouraged to develop their own ideas and put them to use.<sup>6</sup>

The engineers from VERC and WaterAid-B encouraged this innovation by providing technical help and support as required, without dictating ways of doing it. It was not very easy to change the mindset of the sanitation engineers at first but eventually they came to trust the strength and capacity of the communities and documented all the innovations. Today, there are more than twenty models of toilets innovated by communities and the cheapest one costs only Tk.70 (USD 1.27). The table below compares the cost of locally developed models with those developed by external experts.

**Table 2.1 Comparison between CIMs<sup>7</sup> and other low-cost models**

Community innovated model number	Cost of the model in Taka	Cost in US\$	Other low cost models	Cost of model in Taka	Cost in US\$
CIM1	258	4.69	H1	175	3.43
CIM2	130	2.36	H2	345	6.76
CIM3	320	5.81	H3	350	6.86
CIM4	328	5.96	H4	350	6.86
CIM5	105	1.90	H5	400	7.01
CIM6	105	1.90	C1	445	8.72
CIM7	300	5.54	C2	470	9.21
CIM8	160	2.9	C3	500	9.80
CIM9	130	2.36	C4	773	15.15
CIM10	200	3.6	Offset pit home made	223	4.37

It is clear from Table 2.1 that the CIMs are less costly than those designed by outsiders. Interestingly, the community took about 18 months to innovate these models while low-cost models developed by outside agencies took a few years to be developed and were not very popular.

VERC published a booklet on the community evolved latrine models with drawings and pictures and the names of the community designer (VERC 2002). This encouraged the communities even further and members began competing to develop more attractive, durable and low-cost models. Today these villages have all varieties of toilets, some of which are attached to the house, some that have plastic roofs, some with off-set pit and thatched roof, some with concrete ring and slab and some are even the usual modern toilet. Plastics, tin, bamboo, gas pipe, even plastic pans and sockets have been used extensively. Some community members have chosen costlier options. Wealthier people within villages have even constructed fancy, attached bathrooms and toilets.

<sup>6</sup> Please see Annex 1 for diagrams of these community innovations.

<sup>7</sup> CIMs, or Community Innovated Models, are in intensive use in many places in the south and in the north districts.

Within the communities people explored various possibilities to reduce the cost of latrines. For the first time, people were able to adapt or redesign the standard models according to their requirements. When this limitation was removed some people took only the slab and put it on an earthen pit. Others only took two rings and used a wooden plank in place of the concrete slab, while still others used old toilet latrine slabs given to them 10–15 years ago for free under a UNICEF programme that they had been using as a clothes washing plate. It all depended on each family's capacity and need. People started to save money and began with one Reinforced Cement Concrete (RCC) ring toilet. In the Chittagong district, women started to save specifically for the construction of toilets by pooling their resources on a monthly basis and forming Rotating Savings and Credit Associations (ROSCA).<sup>8</sup> Women members pool money each month and one member draws it out to construct her toilet. As soon as each woman is able to construct one, the group disbands. This is an innovative method of micro-credit for funding the acquisition of toilets.

Latrine models have also been modified to local conditions. For example, in southern Bangladesh due to high rainfall, tidal waves and a high water table, the community developed offset pit toilets in which the pit is located away from the squatting plate and is connected with a pipe so as to avoid the splashing of water from the pit. Such modifications and adaptations are by far the most interesting aspect of this approach, and one that has surprised everyone involved in the development of the methodology.

Interestingly, a large number of private entrepreneurs and fabricators have emerged in the nearby local markets in Rajshahi and other districts, who are now importing coloured and low cost plastic pans and fittings from Burma and Thailand to the rural areas of Bangladesh. This natural growth in entrepreneurial activity is directly related to the rise and spread of the demand for toilets in rural areas. As more private sector entrepreneurs are coming in with toilet spare parts that match local needs, VERC's role is changing from that of a manufacturer of concrete rings and slabs to that of simply a facilitator.



*Colourful, light and low-cost plastic pans are available in the shops of remote villages in Bangladesh wherever the community led total sanitation programme is in progress. Local private entrepreneurs are very actively involved in catering to the growing demand of the low-cost sanitary hardware.*

---

<sup>8</sup> ROSCA is a technical term used to denote micro-credit initiatives such as that described here.

They are handing over the supply role to the private sector, and encouraging community people to take up such marketing as new livelihood options. As a result VERC field staff have more time than before to work with the community. Moreover, there is growing competition amongst the private entrepreneurs to supply commodities at lower cost in order to get more customers.

### **2.3.1 Barefoot engineers**

In some villages, talented members of the community were identified who had a natural talent for innovating latrine designs suited to local needs and to soil and environmental conditions. For example, the high rainfall and high water table areas of Bhola and Chittagong district have evolved their appropriate model of toilets through trial and error which differ in structure and design from those of Rajshahi or Chapainawabgunj. Instead of only Dhaka-based engineers of WaterAid-B and VERC struggling to solve the local problems, selected members of the rural community were declared as “Village Sanitation Engineers” and were given total freedom and encouragement to develop local models suited to the needs of different economic and social groups. They have done a wonderful job and have developed almost “no cost” to “low cost” and “medium cost” toilets. These village engineers are now often invited to participate in discussions, seminars and meetings with technical people from VERC, WaterAid-B and other agencies.

Very interestingly, it has been noticed that there exists a great difference in the mindset of the two types of engineers, that is, “formal engineers” and “village sanitation engineers” in developing low-cost latrine models. While the formal engineers struggle hard to lower the cost of latrine models from Tk.500 to Tk.300, the village barefoot engineers did it the other way round. They started with Tk.0 for a latrine with the assumption that it shouldn’t cost any money at all and gradually moved up to Tk.20, then Tk.50 and Tk.100, and so on. When challenged by the formal sanitation engineers about the durability of their low-cost models, the village engineers replied that they change their thatch roofs every couple of years so why should the latrines have a life of decades? They would change them every few years as required.



*Hundreds of low-cost local community-made toilets are surfacing in the rural landscape in community led totally sanitised villages in Bangladesh.*

Fourteen months after the start of the programme an evaluation was carried out that revealed many interesting social, economic and technical innovations. These innovations are documented in Table 2.2.



**Table 2.2 Community innovations identified and documented so far from different areas of the programme**

Technical	Social	Economic	Monitoring/Evaluation	Management	Institutional
<ul style="list-style-type: none"> <li>Village Engineering Group Formation</li> <li>Use of plastic cylindrical socket replacing the prescribed conical one in Tube Well repairs</li> <li>Re-installable rings in single ring latrines designed to suit poor families requirements</li> <li>Homemade Offset Pit (tin pan) toilets, use of bamboo as gas pipe</li> <li>Homemade earthen pit with bamboo gas pipe</li> <li>Bamboo lining inside latrine pit as replacement of cement concrete rings</li> <li>Single ring pit latrine</li> <li>Rexene cloth seal pit latrine to avoid contacts with flies</li> <li>Earthen pit/bamboo gas pipe and RCC platform/squatting plate</li> <li>Use of old and used rickshaw van body as latrine platform</li> <li>Use of earthen pot in latrine construction</li> <li>Use of earthen pot pitcher in latrine</li> <li>VERC latrine model demonstration in villages with price tag for each model.</li> </ul>	<ul style="list-style-type: none"> <li>Imposition of community penalty against open defecation. In Bagmara and in Mochmoi Roypara village it is Tk. 50 per person</li> <li>Children developed play and Gomvira, folk songs and dance from the Rajshahi region, to create awareness (Nachol village) on use of toilets</li> <li>Gift of ring slab in wedding (Nachol) by a Health Motivator.</li> <li>Involving children in awareness raising against open defecation.</li> <li>Imposition of conditions by WATSAN Committee for speedy coverage. Households are asked to install latrine first before taking advantage of the facilities created for water from ring well (Kangarpara Teknaf). Community insisted that VERC field staff temporarily hold further construction of facilities until all the households complete construction of all the toilets.</li> <li>WATSAN Committee to collect contributions and keep in their own bank account for latrine maintenance (Charal Kande village – Sitakunda)</li> <li>Children build path for easy mobility of VERC-HMs in the village</li> <li>Community pressurised the resistant families unwilling to use latrines (Mochmoi)</li> <li>Sermons given by priests of the Mosques (Khudba)</li> <li>Khudba through Mosque</li> <li>Public procession with specific slogans for mass movement on latrine use and stop open defecation</li> <li>Using the loudspeaker of the Mosque in raising awareness and campaigning against open defecation</li> </ul>	<ul style="list-style-type: none"> <li>Using stipend money received from training to purchase latrine slab</li> <li>Formation of PG (small groups) to save money for latrine slab purchase</li> <li>Land donation to poor by the land owner for latrine construction</li> <li>Bamboo, wood and straw contribution by the better-off for latrine construction to the poor</li> <li>Better-off families constructing latrine for use of others (farm labourers) in their own land and in orchards</li> <li>Wholesale price of mango, bamboo, sugarcane and other crops gone up because the purchasers can walk in to the orchards and fields to assess the crop value which they couldn't do before because of filth. Some average price used to be offered to the farmers by assessing crop value from a distance.</li> <li>Selling all the hides of livestock slaughtered after Kurbani (the offering of slaughtered livestock to god during Id), collecting and loaning the proceeds to purchase TW for the poor (Khordakoir Purbapara).</li> </ul>	<ul style="list-style-type: none"> <li>Monitoring Chart developed from community's ideas</li> <li>The community monitors each household in a two stages sanitation ladder. First the shift from open defecation to use of toilets and then the adoption of other hygiene behaviour practices.</li> <li>Community planning and deciding monitoring target for each member of the committee who monitors 3–10 families</li> <li>2–3 member monitoring team for total cleanliness of the village</li> <li>TW management committee responsible for raising fund and maintenance</li> </ul>	<ul style="list-style-type: none"> <li>Using funds meant for latrine construction for creation of water facilities (flexibility in fund use)</li> <li>Lighting arrangement in the mango orchard to prevent open defecation in the night (Bottola – Bholarhat)</li> <li>Village watchmen (Chawkidar) were involved by the sanitation committees to watch if any one was going for open defecation in early morning hours.</li> </ul>	<ul style="list-style-type: none"> <li>WATSAN Committee taking responsibility for collecting money from members and purchasing, collecting and distributing ring slabs to individuals (Khardakour – Bagmara)</li> <li>Weekly savings by small women's group and lottery draw each week to enable one family to purchase latrine. In turn, every family gets a chance. (Mochmoi – Bagmara, Kanjorpara – Teknaf, Nachol)</li> <li>Community's mass sweeping and cleaning campaign of the village. Children's participation in reporting incidences of open defecation to WATSAN committee. (Mochmoi, Nachol and Bholahat)</li> <li>WATSAN Committee keeping watch during night to prevent open defecation (Shankarpoi – Bagmara)</li> </ul>

## **2.4 Community catalysts**

The new methodology also included the use of community resource people to spread the use of latrines within villages and to other villages. These community catalysts included initial users who took responsibility for passing the message on to clusters of households. In fact, members of communities that had first accomplished 100 per cent sanitation in their villages had greater confidence and willingness to spread the programme to others. They took great pride in relating the story of their success to outsiders. Some had a natural flair and ability to convince people to participate in the programme. These people were identified and given training, and were brought to workshops and discussions where community catalysts from all over Bangladesh met and exchanged their stories and experiences. The programme spread further through such exchanges, experience-sharing and learning opportunities. Such spread could not have been accomplished without these mechanisms and without the help of these local resource people. This was a strategic decision to use community catalysts as frontline extension agents, and a systematic investment was made on them.

The multiplier effect of this approach has been noticed in Rajshahi and a few other areas. It spread very fast from large villages to its sub-villages through such community catalysts. However, it has been noticed that the spread was somewhat restricted to family networks. In this way, it did not simply spread from one village to adjacent villages, but also to far-off villages where relations lived. For example, a father took the message from the 100 per cent sanitised village where his daughter was married and spread it in his own far-off village.

The message is also carried rather effectively to different places through roving Muslim priests. Religious leaders tour distant places in groups to spread Islam. One such group of religious people came to Tangile district all the way from Bhola district in the south of Bangladesh. During their stay there, when the group asked for a toilet the host community showed them the way to the open field. The guests expressed surprise and replied that they had stopped open defecation long ago and used toilets instead. During their few days stay they not only dug and constructed temporary toilets for their own use, but also constructed and demonstrated one model for the villagers. This topic was also covered extensively during the religious meeting in that village and villagers seemed to immediately take up the lessons. Such spread also took place through the transfer of teachers between villages and through interaction at major markets.

Community catalysts were very innovative in the methodology they used to spread the programme. One leader of a WATSAN committee of Hazi Gobindapur, Manda in Nawgaon district of northern Bangladesh, developed the slogan 'one fly is deadlier than 100 tigers' to help people understand the havoc that one fly can cause by contaminating food and causing large-scale diarrhoea and even death. He pointed out that flies do not know the boundary of villages and hence it is not enough to completely sanitise one's own village. Unless neighbouring villages are also sanitised, the community is not safe.

Despite such catalysts, there were many instances where people came to VERC's local office and asked them to take up similar programmes in their respective villages. Ideally, people from other villages should approach the WATSAN committees of successful villages instead of requesting VERC's assistance, thus reducing the load on VERC and moving it from the direct implementing role to that of a process

facilitator. However, the village WATSAN committees of totally sanitised villages have not been strong enough to extend sufficient help to other villages.

## **2.5 Community consultants**

Following its innovation, the author introduced the approach in at least two international development agencies in Bangladesh through my consultancy support to their integrated rural development programmes. As an entry-point strategy, community led total sanitation worked particularly well in building a sense of confidence amongst the community in their ability to do things on their own. Starting from the success of total sanitation, communities in a couple of villages have moved in reducing and completely eliminating non-attendance of primary school for children from their villages. Empowered communities in Nilfamari districts in north Bengal have started pre-primary schools on their own with little or no support from PLAN International and have ensured complete coverage of children between three and five years. In the area of health, the community is also monitoring child health and family planning issues using the same approach of total village coverage. In Integrated Food Security Programme (IFSP) of CARE Bangladesh the approach has proved to be very effective in ensuring community participation in many other interventions such as flood proofing, and livelihoods security of people living in waterlogged areas. In the Haor<sup>9</sup> areas of Bajitpur Upozilla of Kishoregonj district, after achieving community led total sanitation, residents have moved onto embankment protection and maintenance, community nursery raising with plants that control flood erosion, village cleaning and even cleaning up neighbouring villages as consultant groups. Not only have hundreds of years of unhygienic practice gone, but newly emerged village leaders from total sanitation campaign in the Haor have initiated fascinating community planning activities which are attracting visitors from other parts of IFSP/CARE Programme in Bangladesh. Moving from community led total sanitation to other areas of livelihood security is the start of a new approach where the empowered community is leading diversified development initiatives.

On the author's suggestions, community catalysts and rural sanitation engineers from earlier successful villages from VERC supported programme districts were sent to different districts in the programme areas of CARE or Plan International as consultants. These community consultants were given consultancy fees of Tk 500 (US\$10) per day by the hiring agencies. The village consultants stayed in different villages and worked with the community to construct and demonstrate the new latrine models innovated by themselves and motivated the communities to clean up their own villages. Wonderful work has been done by many such community consultants who are in great demand by many other agencies and communities in Bangladesh, and with some support these consultants would do a great job in countries neighbouring Bangladesh. A few agencies have been advised to keep records of these community consultants and make them available in websites. Recently the author arranged an exchange visit of staff between VERC, Bangladesh and Concern, Cambodia.

---

<sup>9</sup> The Haor are vast low-lying areas in the north east of Bangladesh which get flooded and remain waterlogged for more than 5–6 months in a year. Densely populated communities live on a few raised land masses in the vast depression. These small island-like villages in the Haor are locally called “Anthi”.

## **2.6 Social dynamics and group formation**

No such effort is ever without its own set of inter-group dynamics, and many emerged under this programme as well. Small identical groups started forming within each village based on similar problems or interests. Many of these groups also became positive internal forces of change.

*The landless:* Landless people generally grouped together to complain that everyone blames them whenever somebody finds excreta on their land. They are blamed first because they are landless and are therefore believed to have nowhere of their own to use. In reality, they don't defecate on others' land but use the bush, forest or land around their working place, and feel great shame in using others' land for such purposes. They are very embarrassed by the allegations.

*Toilet owners:* The owners of sanitary toilets discovered for the first time as a group that they were the worst sufferers because in spite of investing money on toilet construction, they continue to suffer from the consequences of other people's open defecation practices. This realisation came from the flow diagrams drawn by the communities themselves. This group realised that unless everyone in the village stops open defecation contamination and disease cannot be avoided.

*Religious leaders:* Religious people started to realise that the apparently clean clothes of the worshippers were contaminated by human excreta in various ways, especially through the feet of domestic animals. Such clothes are unacceptable for prayer. In most places the *mullahs* started discussing the topic in the mosque, and requested that people use latrines during religious gatherings and weekly prayers.

The programme has resulted in the development of other social dynamics as well. There has been a special effort to include the poor, for example. So far there has been no instance where VERC provided additional support of any kind to the poor. However, there have been instances where the better off people from the village extended help and support to the poor by providing land for latrine construction to the landless, and bamboo, straw and grass for thatching the latrine room.

When communities discovered that open defecation was still being practised by some despite the fact that each household had a toilet, they investigated the matter. They discovered that temporary residents, such as tenants, continued to practice open defecation for lack of an alternative. The communities then pressed landlords to construct latrines for their tenants or alternatively, to allow tenants to use their own toilets. Community pressure and social dynamics ensured that landlords complied with such demands.

The communities also developed innovative community policing and sanctioning methodologies. They undertook collective action, started night patrols to catch offenders that still used open spaces, undertook early morning raids on defecation spots and used the village watchmen to catch and identify offenders. This policing procedure in itself became a community project and fines were imposed on the offenders while financial rewards were offered to the identifier and the witness. Money from the fines supported the WATSAN committees. Even children participated in the project by following offenders and then sticking little name flags on the "offence" so that passers-by could identify the guilty party.

**Figure 2.3 Mapping of village household and hygiene dynamics and social processes stimulated by Entry PRA (Ignition PRA) for moving towards a 100% sanitised village**

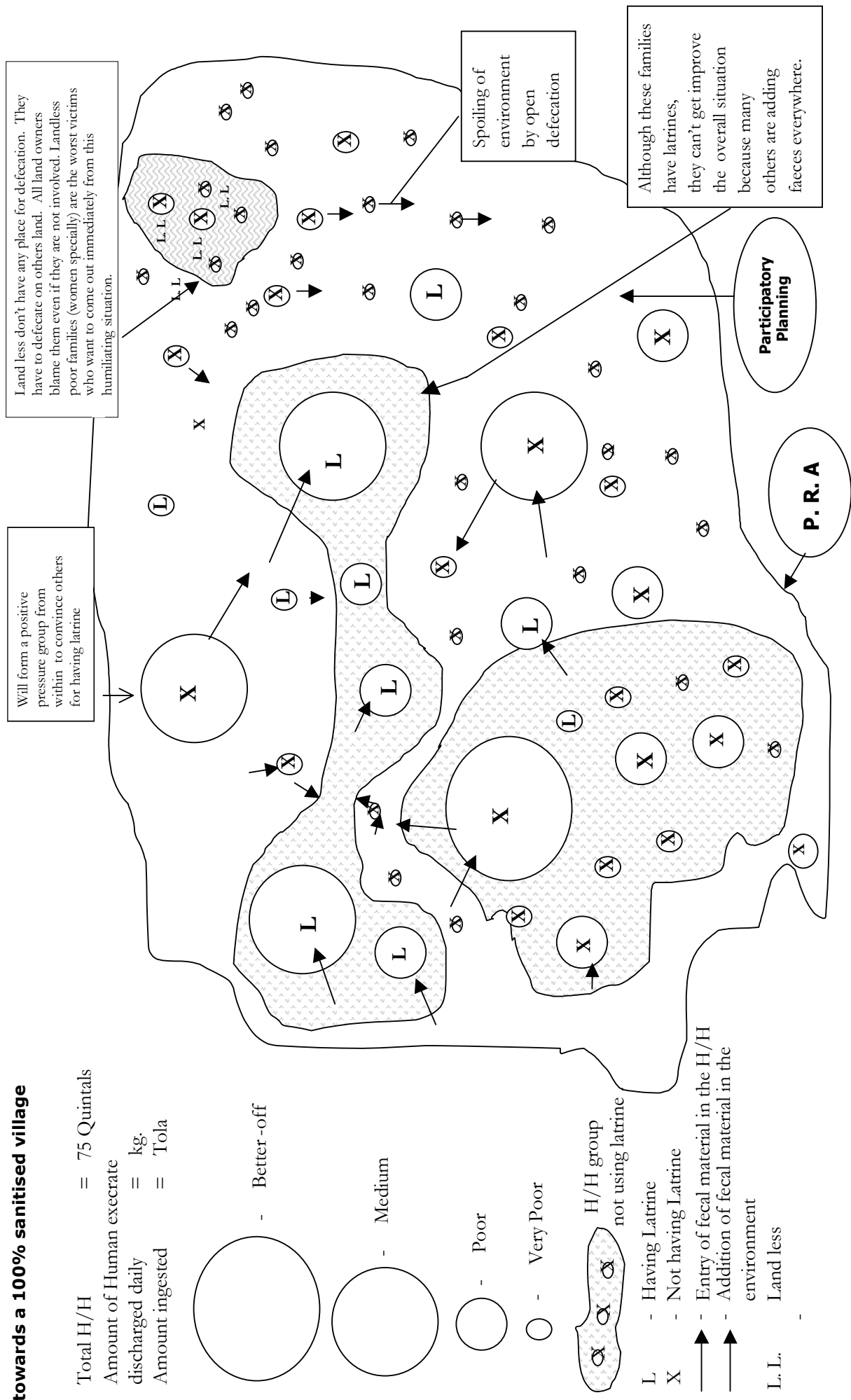

Total H/H = 75 Quintals  
 Amount of Human excrete discharged daily = kg.  
 Amount ingested = Tola

- Better-off
- Medium
- Poor
- Very Poor

- H/H group not using latrine
- L - Having Latrine
- X - Not having Latrine
- - Entry of fecal material in the H/H environment
- - Addition of fecal material in the environment
- L.L. - Land less

## 2.7 Declaring villages as 100 per cent sanitised

As soon as the villagers completed construction of toilets and freed their villages from open defecation, they put up boards in front of the village, which said in Bengali 'No one in this village defecates in the open'. This became a time of celebration and communities from the neighbouring villages were inspired by such displays of success. Since communities had set a deadline for themselves right at the beginning for achieving complete sanitation, they began to compete with one another to stop open defecation within the specified period. Even if all households could not construct a toilet related households shared toilets in order to sanitise their villages 100 per cent as quickly as possible. On a related note, this also meant that the number of toilets in villages was not the same as the number of households. In the very early stage of development of this approach, this idea was given to the successful community and was supported to encourage the neighbouring communities, which worked very well. It often became a point of discussion among the communities in villages who saw the signboard in their neighbouring village yet were still practising open defecation.



*The community of Baidyanthpur, Nizampur in Nachol, of Chapainowabganj district, Bangladesh has put up a signboard at the village entrance declaring their village as an open defecation-free village. There are many such villages where the successful community proudly declares their achievement, which not only enhances and reinforces the strength of the village sanitation committees but also encourages communities of neighbouring villages towards community led total sanitation. The VERC logo is seen on the board because VERC supported the declaration. However, some communities have put up signboards on their own with the name of the Village Sanitation Committee on it.*

The next step now is to declare entire Unions as 100 per cent free from open defecation. Union Parishad chairpersons are working hard to sanitise all villages within a Union in order to be able to achieve this impressive target. Due to the fast spread of the movement, the local elected people's representatives got involved. In at least five Unions leadership of the local government has been convinced and has formed task forces to monitor and support the people's action. The WATSAN groups at the Union level meet every month and have allocated funds to support the local actions of the communities. The Mayor and the District Magistrate of Rajshahi are extending support to such totally sanitised villages and are providing media coverage.

**Table 2.3 Communities declared open defecation-free under Community Led Total Sanitation in Bangladesh (as reported by participating organisations)**

	<b>Name of the organisation</b>	<b>Number of communities (paras) 100% sanitised</b>	<b>Source of information</b>
01	VERC	90	Khandakar Zakir Husain, Director, Water Aid-B, Dhaka.
02	Green Hill (in Chittagong area)	18	Ditto
03	Unnayan Sohojogy Team (UST) (in Char areas)	08	Ditto
04	*World Vision Bangladesh	150	Ditto (As reported to WAB by World Vision in May 2003)
05	Plan Bangladesh	10	Plan, Bangladesh
06	CARE Bangladesh	08	IFSP, Mymensingh
07	Dhaka Ahsania Mission (DAM) (in coastal belt)	18	DAM
	Total	302	

In addition to the villages in Bangladesh summarised in Table 2.3, there are many dozens of villages elsewhere in districts of Bangladesh, in many states of India, and in parts of Cambodia, now experimenting with and using the community led total sanitation approach. Some are initiated by local NGOs, and some by local governments, as indicated in the following reports:

- In Bangladesh, local NGOs have started community led total sanitation initiatives on their own. At least three Unions in Kishorgoni sub-district have started this initiative, according to Maichar Union of Bajitbur Upozila.
- WSP-SA, Dhaka, with advice from the author, has recently undertaken a joint drive involving a number of development agencies in Bangladesh to use the approach to clean up nearly 100 villages lined along the longest sea beach stretched from Cox's Bazar to Teknaf in the southern tip of Bangladesh.
- In India, Gramalaya, an NGO in Tamilnadu state have initiated community led total sanitation and have covered a few villages.
- Zila Parishads (District Council) of Ahmed Nagara and Nanded districts in Maharashtra state, India have covered a few villages and have planned to cover at least 100 more villages in the each district to create learning examples in this year.
- Government of India, Government of Maharashtra and WSP-SA, New Delhi is supporting and facilitating this process, and the author is providing consultancy support to WSP-SA for this scaling up initiative.
- In Pursat and in Siem Reap province of Cambodia, a few villages have been sanitised by the community and work in going on. Concern Cambodia is supporting and facilitating the process.

### **3 Impact of the project**

#### **3.1 Impact on livelihoods**

The programme has had a very positive and profound impact on the livelihoods of many community members, particularly farmers, who now receive higher market prices from outside merchants for bamboo, sugar cane and mango. Previously, bulk purchasers of these products could not go inside the orchards or plantations to measure and assess the quality of the produce because of the filth and human excreta in these areas. The purchasers would simply estimate and calculate the price of the products from outside or from a distance while covering their noses. Now they can go inside and see things from close proximity and the farmers get much better and varied prices for different quality crops. Northwestern districts of Bangladesh are very big mango producing belts and have thousands of square kilometres of mango orchards that had become virtually impenetrable because of their use as defecation sites. The post-sanitisation cumulative gains by the mango farmers of Chapai Nawabgunj and Rajshahi districts are huge.

The programme has also reduced community expenditure on medicine and visits to doctors. The incidence of diarrhoea, which was rampant before, especially during the rainy season, has drastically reduced. This is a huge saving, both in terms of money and in terms of labour hours during the most labour-intensive planting season. Male labourers used to be rendered sick for 1–2 weeks during the rainy season when they could earn the most money. They now save on health cost and also earn more money during the most lucrative period. School attendance rates have also gone up because children do not get ill as often as they did.

The impact of the programme on health is probably greatest in the villages of Haor areas in Bangladesh where the density of households is extremely high due to lack of space. The “Anthis”, as these areas are called, are raised mounds surrounded by vast stretches of medium to deep water which erodes the embankment wall during the rainy season, reducing the size of the mound. Protecting the homestead land from river erosion is a constant struggle. Sometimes there is not enough space to bury or burn the bodies of the dead, and their families must leave the bodies on a floating raft. Boats are the only means of communication, which is highly risky and hazardous in stormy seasons. Diarrhoea, dysentery, cholera and child deaths are very common all year round. During the rainy season, the environment deteriorates further. People live very close together and due to open defecation, huge piles of human excreta are deposited everywhere, filling the air with a foul stench and flies. With the success of community led total sanitation, supported by IFSP/CARE, some Haor villages have experienced the meaning of a clean environment for the first time. In Shibpur and Majchar villages of Bajitpur people reported that on an average each household used to spend Tk 200–300 for treatment and medicines for intestinal problems. By spending only Tk 90 on latrines, these problems have gone. Communities feel confident about their capacities, which has reinforced IFSP/ CARE staff confidence in communities’ abilities to do things without external assistance.

An interesting phenomenon has been noticed in the high-density population areas of Sitakunda in Chittagong district. Here it used to be very difficult to find sweepers for cleaning toilets. The few who



were available charged very high prices. Tk.200 (USD 3.64) used to be charged for cleaning one clogged or overflowing toilet. Now the demand has gone up and sweepers have become community cleaners. Liton Chandra Das of Bansberia union is now charging only Tk.100 and is cleaning many more toilets than he used to clean before. He carries his toilet cleaning kits with his bicycle and is covering 3–4 villages. Due to low cleaning costs, more and more people are asking for his service and Das is earning more, almost Tk.14,500 (USD 263.63) per month from his neighbouring villages. Das feels proud to introduce himself as one of the members of the Rural Sanitation Engineering Group (RSEG), who actively participate in latrine model innovation with others and motivate people to use toilets and keep them clean. Das is even thinking of purchasing a mobile phone to allow clients to reach him more easily.

### **3.2 Impact on women**

Women have been profoundly affected by the programme. Women are usually the natural monitors of health changes in the village and have become strong advocates of the programme because they have noticed the change in diarrhoeal patterns in themselves, their men and their children. They realise that serial diarrhoea, considered a killer, has disappeared, and many expressed surprise that although NGOs and doctors had told them about symptomatic cures for the disease, no one had suggested sanitation as a curative solution. In fact, they understood these links and the long-term health benefits better than most men in the communities did. Women are especially happy to see their children not suffering from diarrhoea regularly and that they are healthier than their mothers were at that age. Regular expenditure on medicine and doctors for treatment of enteric diseases has been reduced drastically.

Women are one of the greatest internal forces for mobilisation and promotional activities in the villages. They start mutual discussions with their neighbours and put agendas forward to their partners for bringing about significant environmental change in their community. Women in these villages have become natural facilitators. It is, therefore, befitting that the WATSAN committees in each village are largely made up of women who monitor health changes and build awareness of personal hygiene and other related issues. They concentrate largely on ending open defecation but they also extend their awareness-raising activities to include things like washing hands regularly, covering food, using hand pumps for drinking water, and talking about personal hygiene.

The sanitation programme has had a profound personal impact on women. In a conservative society where women's modesty is of great importance and significance, open defecation presented a huge moral compromise on morals for many village women, and they had suffered the most under that traditional practice. They also faced harassment while practising this, and to avoid that they would use the fields and orchards only before sunrise or after sunset and had few options during the daylight hours. The significance of moving from an open field to the privacy of one's own home in such a society is immeasurable. One successful community in Borban village in Maharashtra state in India has decided to refuse any marriage proposals for their girls from villages where open defecation continues. Borban village had totally stopped open defecation by January 2003.

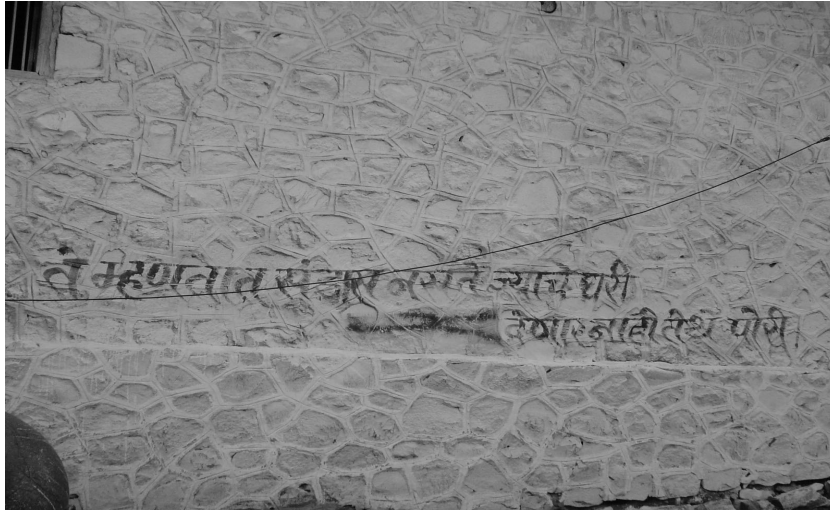

*Wall writings in Matathi language in Borban village of Ahmednagar district in Maharashtra state in India. 'Daughters from our village are not married to villages where open defecation is practiced'.*

#### **4 National and international spread**

The project spread from village to village through a conscious effort by VERC and WaterAid-B who have trained 45 to 50 field staff through intensive interaction with the villages and community resource people. WaterAid-B and VERC invested in the community catalysts that spread the programme, which then attracted other national and regional NGOs. They have trained staff from other organisations, such as World Vision, who are planning to take this initiative to 600 villages in Bangladesh. Danish Agency for Development Assistance (DANIDA) also approached WaterAid-B for staff training and is planning to spread it through Bangladesh, while Bangladesh Rural Advancement Committee (BRAC) has also considered adopting this strategy. DFID in Bangladesh has recently approved GBP 17.45 million for an Advancing Sustainable Environmental Health (ASEH) project to support the spread and scaling up of this community led total sanitation initiative to rural and urban areas through WaterAid-B and their partners. As international donor agencies become interested and approve large sums of money for scaling up, it creates new challenges of quality control and continued involvement of the rural poor.

In December 2001, I was invited by the World Bank WSP-SA's South Asia regional office in New Delhi to deliver a talk and share experience on this innovative approach of community led total sanitation. Senior officials from the State Governments of Maharashtra, Kerala, Andhara Pradesh and from the Central Government and a few national NGOs were invited. On my suggestion in February 2002, the WSP-SA New Delhi and Dhaka organised a three-day regional workshop at Rural Development Academy, Bogra (Bangladesh) for sharing and learning this experience. Forty-five participants attended, including senior government officials including state secretaries, district magistrates/collectors, NGOs, international bilateral funding agencies, and reporters from news agencies in India and Bangladesh. All participants visited at least ten villages in Rajshahi district and had extensive interaction with the communities. The workshop was successful in scaling up and spreading the idea in Bangladesh and India.

By now the approach has spread to hundreds of villages in at least six districts in the north and south of Bangladesh. More than 400 villages have totally cleaned themselves up, covering more than 15,000 families. Their success has also drawn the local government closer. Members of the Union Parishad and

Upozila are taking a keen interest in sustaining and scaling up the programme and are planning to declare totally sanitised Unions soon. The subsidy money is being utilised to develop more facilitators for the ignition process as the demand for good quality facilitators is growing.

The strategy's success has not been limited to Bangladesh alone, as noted above. The author has introduced and tested the approach on a small scale in four other countries in Asia and Africa, with a similar level of response from communities. These include the WASH-21 programme of UNDP Mongolia, Rural Development programme of Concern Cambodia and the WATSAN programme in Zambia.

In India the programme is being introduced in the states of Maharashtra (by the state government) and Tamilnadu (by an NGO). The state government of Maharashtra with the World Bank's WSP-SA has recently introduced the approach in two pilot districts, Ahmednagar and Nanded, where the progress is impressive. At least ten villages have been totally sanitised by the community without any external subsidy during the last three to four months. The "Zila Parishad" (District Council of the local government) and the district administration have successfully introduced the approach in these two districts where the government officials, field level extension staff, elected people's representatives of the Panchayat and NGO workers are being trained on the community led total sanitation approach in villages. After introduction, in March 2003 elected people's representatives, Government and NGO staff from these pilot districts were taken to Bangladeshi villages for exposure visits and a sharing of experiences. A unique feature of the approach is its efficiency in getting the message across to the rural community, irrespective of the external implementing/facilitating agency. This is already reflected in two countries' experience. In Bangladesh it has been successful with the facilitation of national and international NGOs whereas it is being implemented by Government agencies in India. In both cases the results are impressive. In Trichi district of Tamilnadu state in India a number of villages have also been cleared from open defecation by the community themselves with the facilitation of a local NGO "Gramalaya". Other states in India are planning to start a similar effort with communities with support from Rajeev Gandhi Water Mission of the Government of India.

In Zambia, the approach was introduced in Monze district during an evaluation of the WaterAid supported programme in 2000 where initial responses from the community were very encouraging. Traditionally the Environmental Health Technicians (EHT) of the department of water and sanitation (DWASHE) had implemented such projects and people had had many complaints. The freedom of this approach empowered the people to take the initiative and it has been more effective and successful. In 2001, the author introduced the approach in Uganda through the district development agencies under the decentralised district-planning programme. It proved equally successful in a number of villages in Kibale district in Uganda.

**Figure 4.1 Social map of Choobana village, Monze district, Zambia showing all the households with and without latrines dish racks and refuse pits**

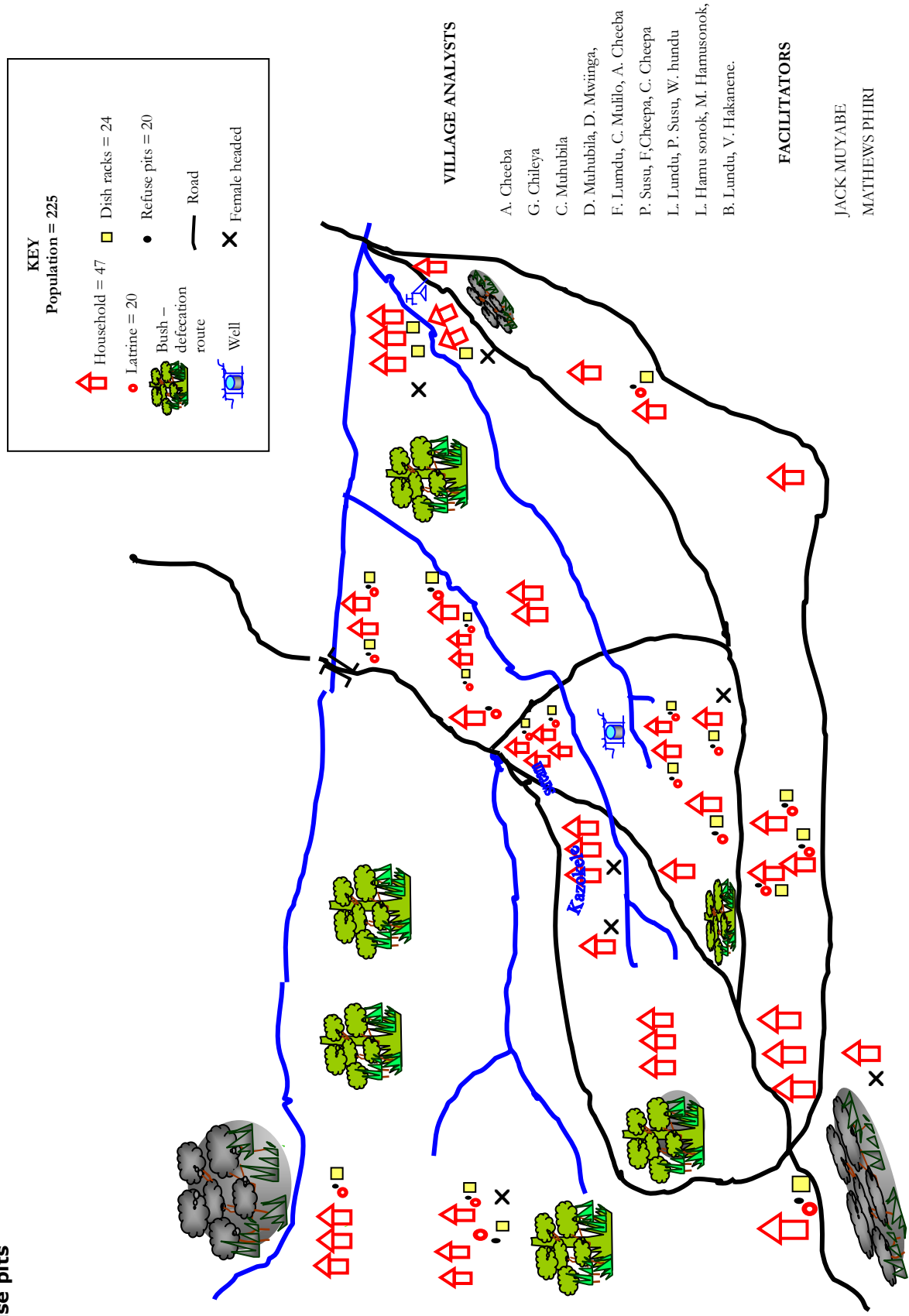

The response of the rural community towards this approach is fascinating in Pursat and in Siem Reap Province in Cambodia where the author has recently introduced it through training workshops for the staff of Concern, Cambodia, selected members of the local Commune Councils and local NGOs organised. The Capacity Building for Rural Development (CBRD) programme of Concern, Cambodia has recently trained more than 50 of their field staff, partner NGOs, Commune Council members and village leaders in the approach and local actions are being initiated by the community. In at least five villages the empowered communities have vowed to totally stop open defecation. It is found to be a very good entry point strategy in rural development programmes where the community has a chance to demonstrate their inherent capacity to solve their own problems. But it is too early to say how the programme will spread in Cambodia due to factors such as the recent history of dictatorial government, high influence and control of different political parties in different areas, extensive open range pig rearing by villagers (dogs and pigs often eating human excreta is a common scene in rural Cambodia), and seasonal flooding and inundation in the Mekong river basin.

## **5 Points of departure**

The previous sections indicate that this programme differs in significant ways from other sanitation programmes. The major point of departure is the total absence of subsidies. The programme receives no external financial contributions. This has saved VERC a lot of money that would previously have been used as subsidies, and this saving has been utilised instead in the spread and scaling up of the programme, and on training community resource people for this purpose. VERC has invested these savings in the community catalysts themselves, taking them to different regions, workshops and seminars, and training activities in order to build their capacity to spread the programme. The same is being done in the IFSP/Mymensingh region in the programmes of CARE Bangladesh and Plan Bangladesh. Although CARE programmes still provide good amounts of subsidy for latrine construction, the recent experience from IFSP, Mymensingh is sending a different message to other programmes of CARE in general. Under the earlier project, funds went into non-replicating or non-productive activity like construction. Now funding is used to develop resource people who then spread the project and enable its replication.

Furthermore, most other sanitation programmes measure the success of their initiatives on the basis of numbers of latrines constructed within a given period of time. This initiative measures its success on the basis of the use of the latrines constructed, and more importantly, on the complete end to open defecation. Latrine construction means little if open defecation continues alongside it. The central point of this programme was not the meeting of targets but motivation and awareness raising. The granting of land to landless people for the construction of latrines was unprecedented in the history of these villages.

The programme has encouraged a lot of inter-village communication and contact and this is also unprecedented. The programme attracts a lot of visitors, who are led on tours by local resource people. Spontaneously, people from the neighbouring villages have begun to visit the totally sanitised villages and then invite the women and men who led the total sanitation programme back to their own communities.

The leaders from the villages of early innovations have become very popular in their respective areas and even people from outside the district and the country come to see their success. This regular flow of visitors has been an added incentive to keep the toilets, homes and streets clean because people can drop in at any time.

Another major point of departure for the programme was its flexible use of technology. While earlier programmes had offered three or four fixed toilet models at a cost of about Tk.200–300 (USD 3.63–5.45), this programme offered complete freedom to the community to come up with their own cheap, innovative and affordable models. Earlier, the available technology was always a limiting factor. When it became flexible it expanded to a free-for-all innovation-friendly environment that has resulted in 30 models to date. The rise of the private sector in catering to local needs and encouraging small entrepreneurs in becoming suppliers is also interesting and important. In some cases, people even opted for costlier models than those initially provided to them by the projects. The flexibility gave people the chance to do whatever they could afford. Engineers had a hard time adapting to this new approach because they had to undergo a difficult process of behavioural change to allow them to learn from the community. In the end, not only did they learn but they also helped the communities fine-tune their models.

The process of recruitment was another interesting point of departure. People were recruited not only on the basis of their communication skills, but more surprisingly, on their singing and dancing ability. The facilitators believed that the project required informality and frankness, with people who communicated easily and were open, relaxed, uninhibited and not “intellectually constipated”!

## **6 Limitations of the approach observed to date**

A number of issues have emerged that can be considered as limitations of the approach.

- The success of this programme is largely dependent on the quality and skills of the facilitators who ignite the communities’ participation and eventually empower them to sanitise their environment. The lack of good quality PRA facilitators, who are the most important tool of this approach, could be a major limitation. However, new facilitators can be trained by VERC, Water Aid, and many other agencies and most importantly by the successful communities.
- A greater challenge is attitudinal change within large developmental institutions, such as national and international NGOs and government departments. Such institutions must undergo an attitudinal transformation for a more enabling internal environment that has faith in the capacity and capability of communities to sanitise their villages without subsidy. Without such a change the programme cannot spread very far. Some agencies promote sanitation both with and without subsidy through different local partners, which raises questions about their confidence in community capacity.
- Similarly, this approach requires institutions involved in WATSAN activities to invest in staff capacity building at the grassroots level. Such training and capacity building of a large number of field

staff can be time consuming and resource demanding, with an openness to learning from other institutions and communities and therefore many organisations are unwilling to do so. Many institutions also still believe that the solution lies in just building infrastructure. If this mind-set does not change, it could be a major limitation to further spread.

- Another limitation that has been observed is the weakness of the WATSAN committees formed in villages. A total of 400 or more WATSAN committees have been formed so far, none of which have any financial, technological or facilitation capacity to take the approach forward as a programme. Unless these committees are strengthened systematically to emerge as strong community organisations, the risk of losing the momentum will remain.
- Another limitation, which might crop up at any time, is a possible clash between the subsidised toilet construction approach of a few agencies and this 100 per cent sanitation without subsidy approach. People might begin to feel that they should wait and avail the opportunity of subsidy given by external agencies instead of investing their own time and money. This could slow down the speed of the programme.
- The strength and uniqueness of this approach are its innovations in technology, community mobilisation, scaling up, institutional capacity building and programme management by the lead agencies. If the programme continues to expand substantially, one limitation could be VERC's and similar other institutions' ability to cope with and adapt to growing challenges and to provide continuing professional institutional support.

## **7 Lessons learnt and recommendations**

This new and empowering approach towards the provision of services and infrastructure has a number of recommendations to make that have serious policy implications for other such programmes.

- 1 It is not the subsidy that is important, it is the people's self-respect. Projects should never use the word subsidy.
- 2 Organisations should undertake participatory analysis through free and frank learning without obvious, pressing targets. They only need to start the analysis and the facilitation and let the community do the rest. They must also demonstrate flexibility to allow the community to decide whether they need the subsidy or not.
- 3 Participatory approaches trigger change within communities, and organisations must watch out for triggering moments. A triggering moment in this case is the initial embarrassing moment when the facilitators are taken to the dirty parts of the village. The whole success depends on triggering the inner feelings of self-respect of the community to get them to take the initiative.
- 4 A relaxed, slow pace should be followed during a tension-free facilitation process. Continuous learning and facilitation all along the process is needed until communities develop their own process facilitators and catalysts to ignite other villages.

- 5 The needs of the community must be foremost and the facilitators should work according to them. The solidarity of the community and the idea of people helping each other are very important. Village leaders and teachers must be involved and fully informed from the outset. Everything should, of course, be done at the convenience of the community and not the facilitators.
- 6 This is a software led approach where inherent potential and social capital of the community is harnessed and the development agency plays a facilitating role and the hardware comes later.
- 7 Involving the local government institutions from the beginning is important for sustainability. As the programme gradually covers 100 per cent of the households of the village and the news starts spreading, local government officials feel happy to be credited with the success and their ownership of the programme grows faster. This is when the implementing agencies should start withdrawing quietly after handing over to the village committee and to the local government institutions. Institutional linkage building, advocacy and follow-up support are important for sustainability.
- 8 Moving from a target driven subsidised approach to 100 per cent sanitised village approach without any subsidy would not have been possible without institutional transformation within VERC from a top-down approach to this bottom-up one. It realised that it would have to empower its own front line staff before the staff could empower villagers. It was no longer involved in constructing free toilets but had started the much harder work of convincing and motivating people. An enabling environment for the grassroots field worker was created. It is difficult to say if many institutions would be prepared to undergo such a change of institutional attitude and style of management to trigger self-mobilisation. This may be one of the most important challenges. It is easier to facilitate and empower communities to clean up their villages than to initiate top-down changes/transformations, bureaucratic institutional culture control and domination. Future spread of the approach will largely depend on the attitude of larger institutions and their ability and willingness to change and allow adequate freedom to their field/front line staff, local partners organisations, NGOs and CBOs.
- 9 The relationship between WaterAid-B and VERC was also important. WaterAid-B funded VERC's activities, and when they realised that the money saved from the subsidy was large, they were flexible in allowing VERC to use it for the spread of the programme instead of expecting it back. They remained flexible to this new approach and allowed their own work to change from construction and subsidy to empowerment and extension work. Institutional culture, attitude and relations with other agencies are of paramount importance in creating a healthy working environment.



## Annex 1 Community innovated toilets

This section presents some of the community innovated models of toilets developed in different regions of Bangladesh. Under the programme, people in rural communities with innovative ideas were identified, encouraged and their work recognized. These empowered individuals contributed substantially in developing low cost models and in helping others in constructing toilets in their respective villages and in neighbouring villages. They have been recognized as Rural Sanitation Engineers. They are respected by the community and are in demand in the area. These models of latrines suit the needs of different well-being groups and are more popular than externally prescribed models. After using low cost models for a few years, some families are shifting to costlier models depending on their financial capacities. Many feel that there is no harm in changing/reconstructing their toilets after every two to three years when they have to change the thatched roof of their own houses in any case. The author is grateful to VERC for permission to reprint these images (see VERC, 2002).

### Community innovated model 1

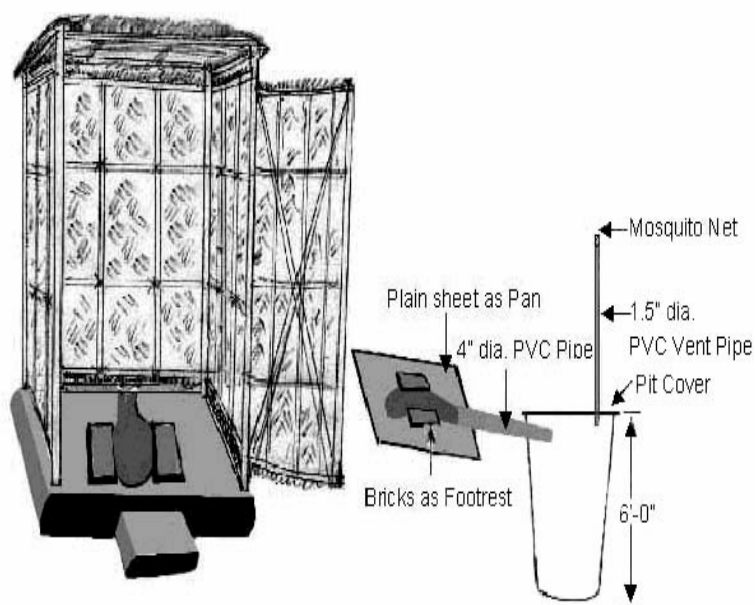

**Innovator:** Community Sanitation Engineer Md. Habibur Rahman Shaikh Para, Village- Mochmoil, Union – Shuvadanga Upazila – Bagmara, District. – Rajshahi

**Innovation Period:** July 2000

**Cost of Materials without Superstructure:** Tk.258.00

**Advantages:**

- Cost is low compared to other options
- Materials are available within locality
- Small amount of water can flush the toilet
- More durable compared to direct pit latrine options

**Disadvantages:**

- Side of the pit may collapse with heavy rainfall
  - More space needed for installation
- Longevity:** ( Calculated on the basis of a family size 6 and a 6ft deep pit)  
Approximately 2–3 Years

## Community innovated model 2

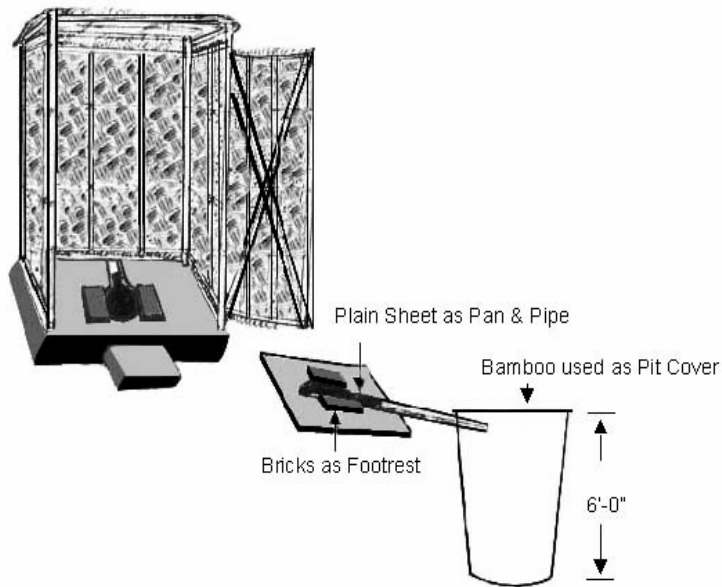

**Innovator:** Community Sanitation Engineer Md. Zafir Uddin & Md. Ashraf, Village – Shankarpai, Union – ShuvadangaUpazila – Bagmara, District – Rajshahi

**Innovation Period:** October 2000

**Cost of Materials without Superstructure:** Tk.130.00

**Advantages:**

- Cost is very low compared to other options
- Materials are available within locality
- Small amount of water can flush the toilet
- More durable compared to direct pit homemade options

**Disadvantages:**

- Side of the pit may collapse with heavy rainfall
- More space needed for installation

**Longevity:** (Calculated on the basis of a family size 6 and a 6ft deep pit) Approximately 1.5–2 Years

## Community innovated model 3

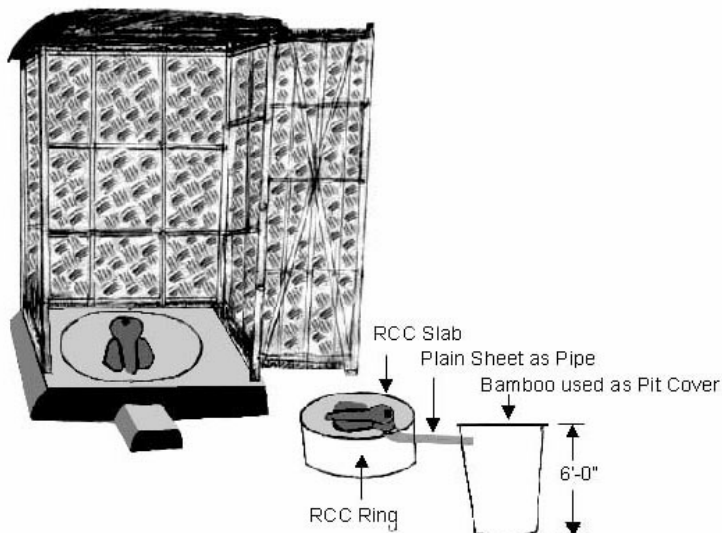

**Innovator:** Community Sanitation Engineer Md. Osman, Ray Para, Village - Mochmoil, Union – Shuvadanga Upazila – Bagmara, District – Rajshahi

**Cost of Materials without Superstructure:** Tk. 320.00

**Advantages:**

- Cost is low compared to other options
- Materials are available within locality
- Small amount of water can flush the toilet
- More durable compared to other options

**Disadvantages:**

- Side of the pit may collapse with heavy rainfall
- Strong odour may come out at the time of use

**Longevity:** ( Calculated on the basis of a family size 6 and a 6ft deep pit) Approximately 2–2.5 Years

### Community innovated model 4

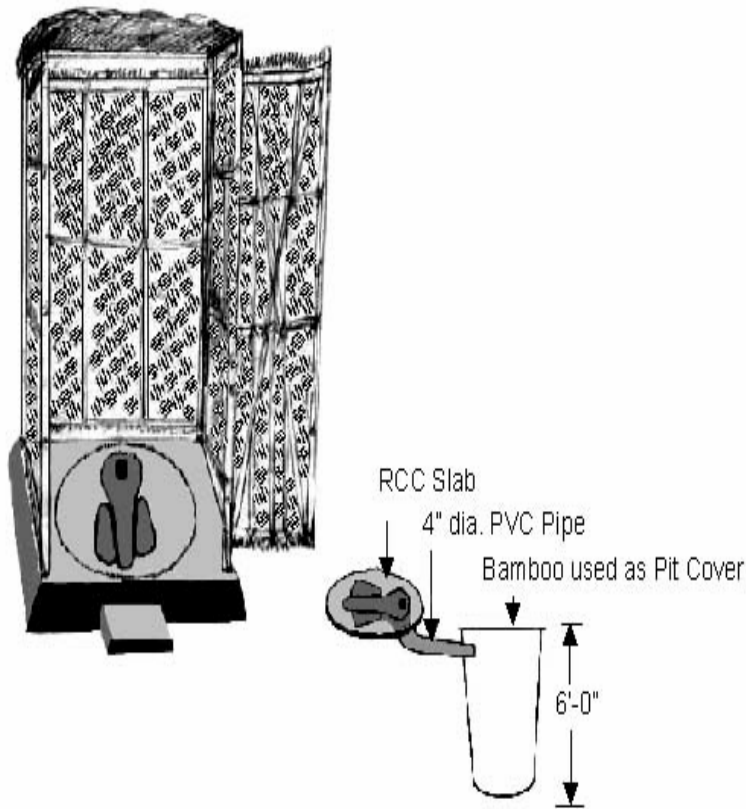

**Innovator:** Community Sanitation Engineer Md. Majibur Rahman, Village – Bottola, Union – Daldali, Upazila – Bholahat, District – Chapai Nawabgonj

**Innovation Period:** July 2001

**Cost of Materials without Superstructure:** Tk.328.00

**Advantages:**

- Cost is low compared to other options
- Materials are available within locality
- Small amount of water can flush the toilet
- More durable compared to other direct pit homemade options

**Disadvantages:**

- Side of the pit may collapse with heavy rainfall
- Strong odour may come out at the time of use

**Longevity:** (Calculated on the basis of a family size 6 and a 6ft deep pit)

Approximately 2-3 Years

### Community innovated model 5

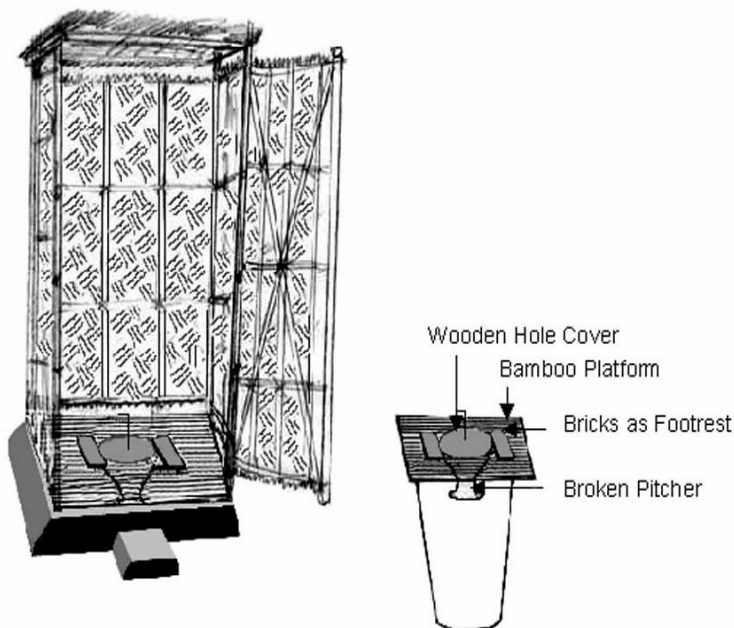

**Innovator:** Community Sanitation Engineer Md. Babul Shaikh, Village – Hariabari, Union – JambariaUpazila – Bholahat, District – Chapai Nawabgonj

**Innovation Period:** June 2001

**Cost of Materials without Superstructure:** Tk.105.00

**Advantages:**

- Cost is very low compared to other options (lowest cost)
- Materials are available within locality
- Easy replacement (if land is available)
- Small amount of water can flush the toilet

**Disadvantages:**

- Side of the pit may collapse with heavy rainfall
- Strong odour may come out at the time of use
- Stool drops and rebounds water in monsoons as the water level goes up

**Longevity:** (Calculated on the basis of a family size 6 and a 6ft deep pit)

Approximately 1-1.5 Years

## Community innovated model 6

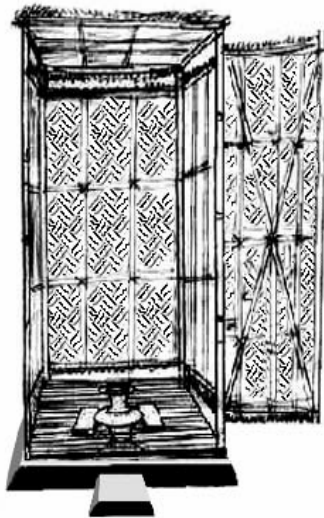

**Innovator:** Community Sanitation Engineer Md. Golam Mostafa, Village – Bajendrapur, Union – Fatepur; Upazila – Nachol, District – Chapai Nawabgonj

**Innovation Period:** July 2001

**Cost of Materials without Superstructure:** Tk.105.00

**Advantages:**

- Cost is very low compared to other options (lowest cost)
- Materials are available within locality
- Easy replacement (if land is available)
- Small amount of water can flush the toilet

**Disadvantages:**

- Side of the pit may collapse with heavy rainfall
- Strong odour may come out at the time of use
- Stool drops and rebounds water in monsoons as the water level goes up

**Longevity:** (Calculated on the basis of a family size 6 and a 6ft deep pit) Approximately 1–1.5 Years

The following latrine models were mostly designed by outside development professionals with local needs and requirements in mind. Some were used by the community but they were not very popular amongst the poor families. The local communities rejected most of the models. This clearly re-establishes the fact that the community knows their own needs very well and can work out solutions of their own if empowered.

## Option – H1 General homemade latrine

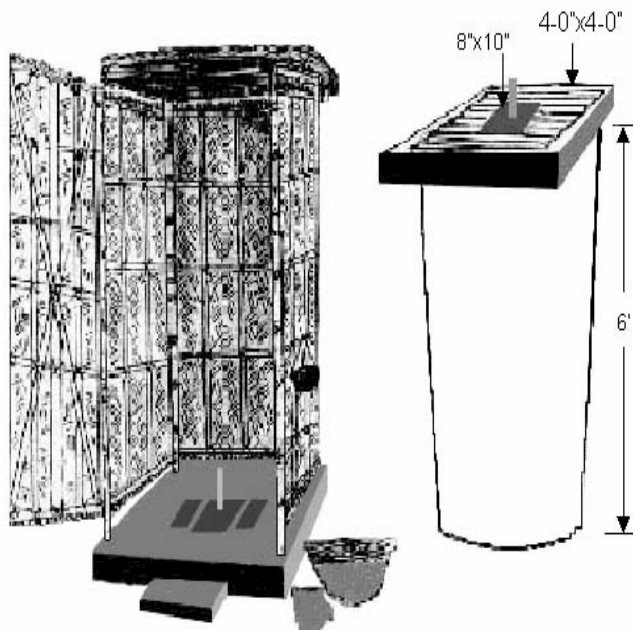

**Cost:** Tk.175.00

**Advantages:**

- Cost is low compared to other options
- Materials are available within locality
- Easy replacement (if land is available)

**Disadvantages:**

- More possibility of damage to the base without super structure
- Less durable
- Side of the pit may collapse with heavy rainfall
- Strong odour comes out when the hole cover is opened
- Stool drops and rebounds water in the monsoons as the water level goes up
- (Calculated on the basis of a family size 6 and a 6ft deep pit)

Approximately 10–12 months

### Option – H2 Homemade latrine with bamboo lining

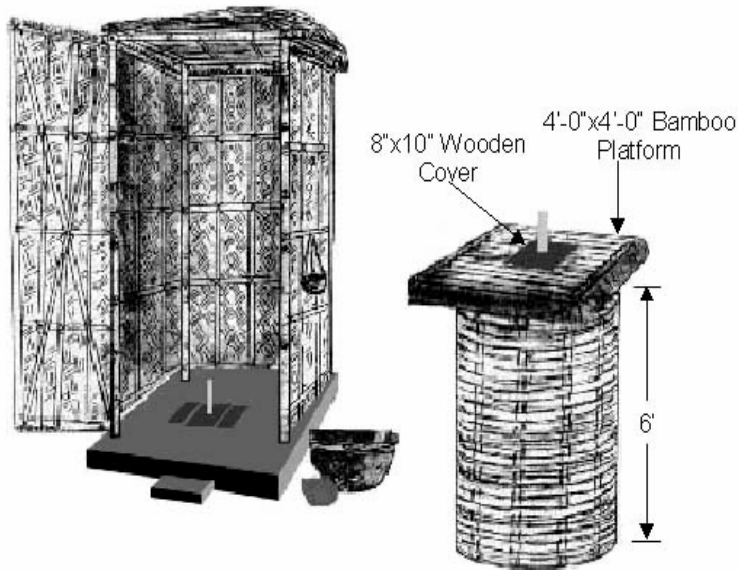

**Cost:** Tk.345.00

**Advantages:**

- Cost is low compared to concrete latrine
- Materials are available within locality
- More durable than option-H1
- No possibility of collapse of the side of the pit
- Easy replacement (if land is available)

**Disadvantages:**

- Cost is mid range of homemade latrines
- More possibility of damage to the base without super structure
- Strong odour comes out when the hole cover is opened
- Stool drops and rebounds water in monsoons as the water level goes up

**Longevity:** (Calculated on the basis of a family size 6 and a 6ft deep pit)  
Approximately 1–2 years

### Option – H3 Homemade latrine using earthen pots

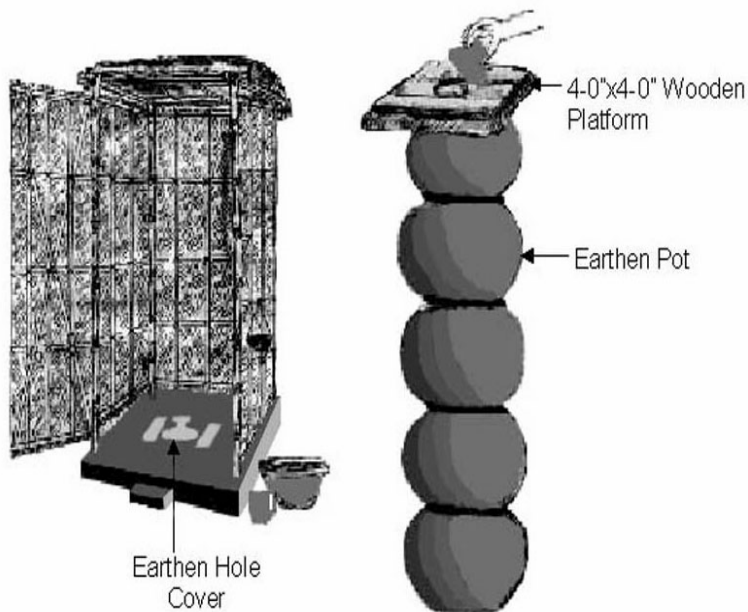

**Cost:** Tk. 350.00

**Advantages:**

- Cost is low compared to concrete latrine
- Materials are available within locality
- More durable than option-H1& H2
- No possibility of collapse of the side of the pit
- Easy replacement (if land is available)

**Disadvantages:**

- More possibility of damage to the base without super structure
- Strong odour comes out when the hole cover is opened
- Low wastewater soaking will take place if the number of holes are not sufficient
- Stool drops and rebounds water in monsoons as the water level goes up

**Longevity:** (Calculated on the basis of a family size 6 and a 6ft deep pit)  
Approximately 1.5–2 years

### Option – H4 Homemade latrine using pottery rings

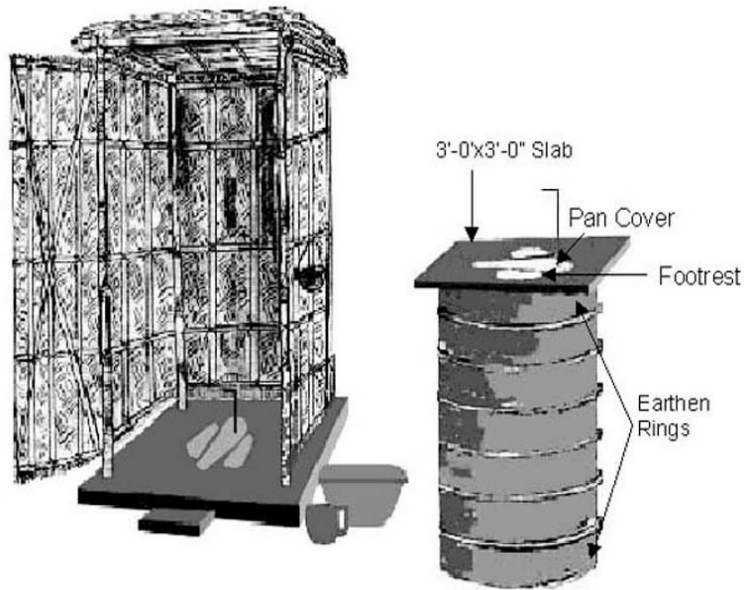

**Cost:** Tk. 375.00

**Advantages:**

- Cost is low compared to concrete latrine
- Materials are available within locality
- More durable compared to other homemade options
- No possibility of collapse of the side of the pit

**Disadvantages:**

- Strong odour comes out when the hole cover is opened
- Low wastewater soaking will take place if the number of holes are not sufficient
- Stoll drops and rebounds water in monsoons as the water level goes up

**Longevity:** (Calculated on the basis of family size 6 people, depends on the number of rings) Approximately 2–3 years

### Option – H5 Homemade latrine with rexin seal

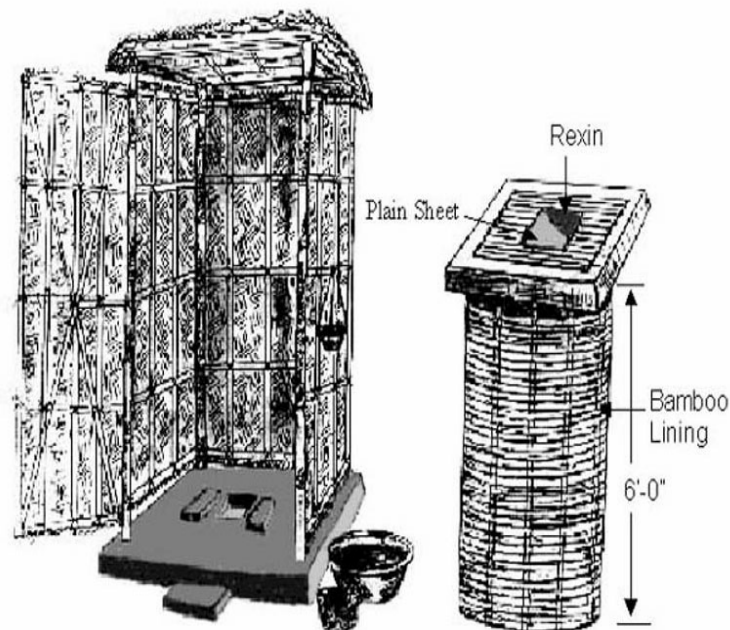

**Cost:** Tk. 400.00

**Advantages:**

- Cost is low compared to concrete latrine
- Materials are available within locality
- More durable than option-H1, H2 & H3
- No possibility of collapse of the side of the pit
- Needs no extra cover on the hole
- Easy replacement (if land is available)

**Disadvantages:**

- Cost is the highest of homemade options
- More possibility of damage to the base without super structure

**Longevity:** (Calculated on the basis of a family size 6 and a 6ft deep pit) Approximately 2–2.5 years

### Option – C1 VERC key hole pit latrine with pan

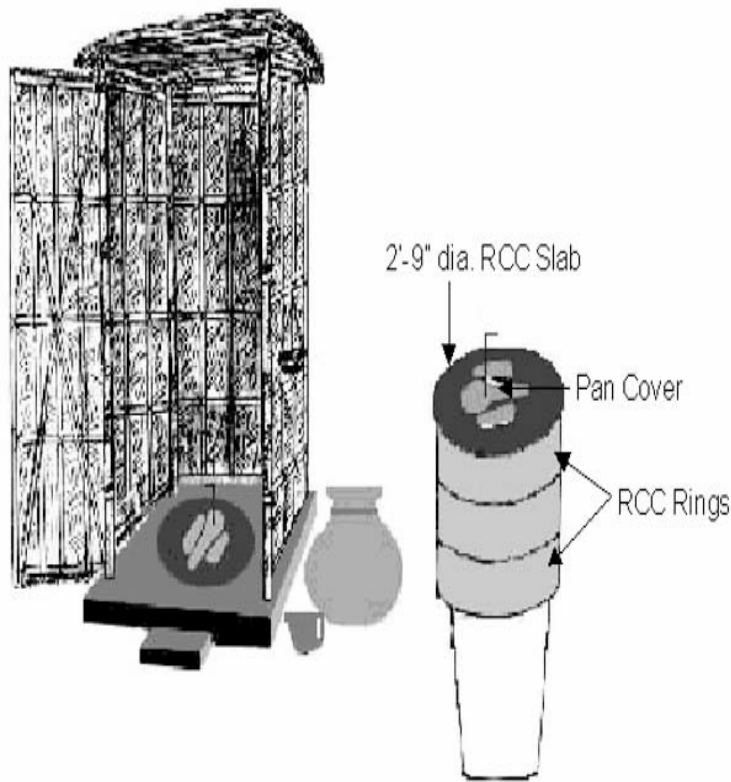

**Cost of Materials without Superstructure:** Tk. 445.00

**Advantages:**

- No possibility of collapse of the side of the pit
- Easy sliding down of faeces for which less water needed for flushing
- A low cost option compared to other concrete latrine
- Easy to construct and requires less time
- Long lasting compared to home made direct pit options

**Disadvantages:**

- Flies, mosquitoes and other insects can easily enter the pit if the pan cover is not properly used
- Strong odour comes out when the pan cover is opened
- Visibility of faeces inside reduces the users tendency
- Stool drops and rebounds water in monsoons as the water level goes up

**Longevity:** (Calculated on a family size of 6 and 3 concrete rings being used in the pit) Approximately 2–3 years

### Option – C2 Water seal latrine



**Cost:** Tk. 470.00

**Advantages:**

- No possibility of collapse of the side of the pit
- Flies, mosquitoes and other insects cannot enter the pit
- A low cost option compared to plastic pan & offset pit latrine
- Low emittance of foul odour
- Long lasting compared to homemade direct pit options
- Can be installed close to the living room

**Disadvantages:**

- More technicalities and amount of time involved
- Risk of damage/breakage of the gooseneck during transportation
- More water needed for flushing

**Longevity:** (Calculated on a family size of 6 and 3 concrete rings being used in the pit) Approximately 2–3 years

### Option - C3 Water seal latrine with plastic pan



**Cost:** Tk. 500.00

**Advantages:**

- No possibility of collapse of the side of the pit
- Flies, mosquitoes and other insects cannot enter the pit
- A low cost option compared to offset pit latrine
- Low emittance of foul odour
- Long lasting compared to other options except offset pit latrine
- Can be installed close to the living room
- Decent looking pan and easy to maintain

**Disadvantages:**

- More costly so it is not affordable to majority of the population
- More technicalities and amount of time involved
- Risk of damage/breakage of the goose neck during transportation
- More water needed for flushing

**Longevity:** (Calculated on a family size of 6 and 3 concrete rings being used in the pit) Approximately 2.5–3 years

### Option – C4 Offset pit latrine

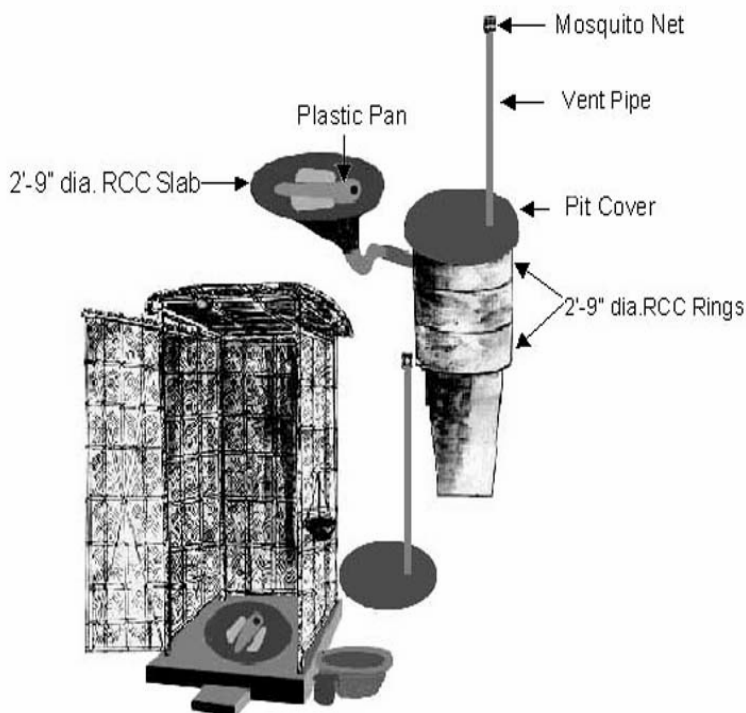

**Cost:** Tk 773.00

**Advantages:**

- No possibility of collapse of the side of the pit
- Flies, mosquitoes and other insects cannot enter the pit
- Low emittance of foul odour
- Long lasting compared to other options
- Can be installed close to the living room
- Comparatively nice looking and more acceptable

**Disadvantages:**

- More costly so it is not affordable to the majority of the population
- More space needed for installation
- More water needed for flushing

**Longevity:** (Calculated on a family size of 6 and 3 concrete rings being used in the pit) Approximately 2.5–3 years



## Offset pit homemade latrine

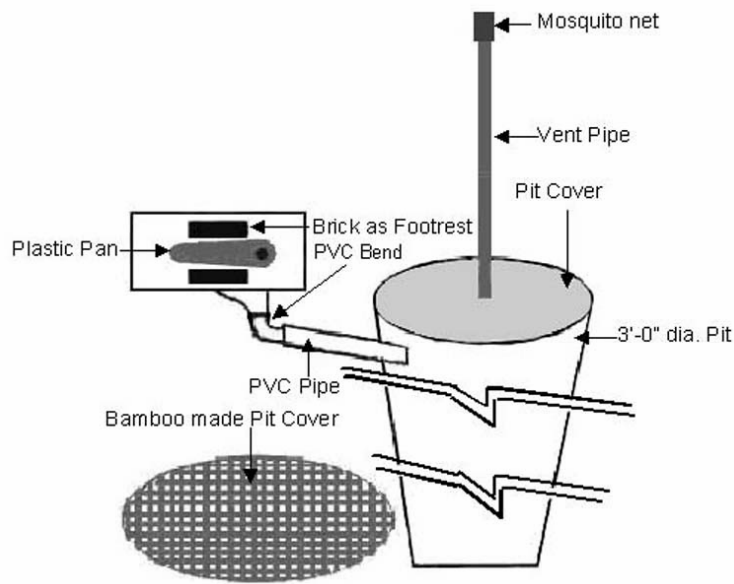

### Cost of Materials without Superstructure:

Plastic Pan 1 No. @ 30/-	= Tk. 30.00
4" dia. PVC Bend 1 No. @ 25/-	= Tk. 25.00
4" dia. PVC Pipe 3'-0" @ 20/-	= Tk. 60.00
1.5" dia. PVC Vent Pipe 6'-0" @ 8/-	= Tk. 48.00
Bamboo 1 Nos. @ 50/-	= Tk. 50.00
Brick 2 Nos. @ 2.50	= Tk. 5.00
Polythene 1 Yard @ 5/-	= Tk. 5.00
<b>Total</b>	<b>= Tk. 223.00</b>

### Advantages:

- A low cost option compared to other latrine
- Easy sliding down of faeces for which less water needed for flushing
- Flies, mosquitoes and other insects cannot enter the pit
- Low emittance of foul odour
- Long lasting compared to other homemade options
- Can be installed close to the living room
- Comparatively nice looking and more acceptable

### Disadvantages:

- Side of the pit may collapse with heavy rainfall
- More space needed for installation

**Longevity:** (Calculated on a family size of 6 and 3 concrete rings being used in the pit) Approximately 2.5–3 years

## Bibliography

- Ahmed, S.A., 2002, 'Water and sanitation program', personal communication, based upon 'Health care expenditures in Bangladesh' in *Health Situation and Health Care Expenditures in Bangladesh, Evidences from Nationally Representative Surveys*, Bangladesh Bureau of Statistics, April 1999
- Kar, K., Nkoloma, H.C. and Oyoo, P., 2000, 'Participatory evaluation of Water Aid Programme in Munze district of Zambia', unpublished consultancy report, London: WaterAid UK
- Kar, K., Ahmed, K.A., Saha and Yesmin, 2000, 'Self-mobilised Water and Sanitation Programme in Bangladesh – a community empowerment approach', unpublished consultancy report for WaterAid Bangladesh, Dhaka
- Kar, K., Bajracharya, D., Khan, M. and Mudgal, A., 1998, 'Report of the Participatory Evaluation of VERC's Rural Safe Water Supply and Environmental Project', unpublished consultancy report for WaterAid Bangladesh, Dhaka
- Kar, K., Avirmed, B., Gongor, G., Ulambayar, T. and Urtnasan, B., 2000, 'Participatory evaluation of National Water Supply, Sanitation and Hygiene Education Programme for the 21<sup>st</sup> century of UNDP in Mongolia', unpublished evaluation report on WASH-21 submitted to UNDP, Ulaanbaatar, Mongolia
- Kar, K. with Ahmed, K.A., Hasan, M., Hossain, Y., Hossain, Z. and Khandakar, S., 2001, *Report of the Mid Term Evaluation of VERC, Water Aid, Water Sanitation and Hygiene Promotion Project, Phase III, Totally Sanitised Village Approach, (100% SVA)*, Dhaka: WaterAid Bangladesh
- Village Education Resource Centre (VERC), 2002, *Shifting Millions from Open Defecation to Hygienic Latrines*, Dhaka: Dhanshiri Printing and Publishing Co.
- WaterAid Annual Regional Network Meeting Minutes, 2002, Pondicherry, India, January
- WELL (Resource Centre Network for Water, Sanitation and Environmental Health), 2001, 'Bangladesh environmental health scoping study', (Simon Bibby, Bilqis Hoque and Caroline Hunt, WELL Task 628), unpublished consultancy report, Loughborough/London: WELL